



Contents

PROCEDURES..... - 3 -

GENERAL PROCEDURES GUIDELINES - 4 -

 RESPONSIBILITIES - 4 -

BACKUP PROCEDURE - 5 -

BLIND BOX PROCEDURE..... - 6 -

BOTTOMHOLE BUMPER SPRING PROCEDURE - 8 -

BRAKE ADJUSTMENT PROCEDURE..... - 10 -

BROACHING TOOL PROCEDURE - 11 -

CATADYNE HEATER LIGHTING & SHUT-DOWN PROCEDURE - 12 -

CAISSON ENTRY PROCEDURE..... - 13 -

EQUIPMENT INSPECTION PROCEDURE..... - 14 -

EQUIPMENT MAINTENANCE PROCEDURE - 15 -

GAS DETECTION PROCEDURE - 16 -

GAUGE RING PROCEDURE..... - 17 -

GENERAL DRIVING & TRAVEL PROCEDURES..... - 18 -

HARASSMENT & VIOLENCE PROCEDURES - 20 -

H2S TRAILER PROCEDURE - 21 -

HYDROSTATIC LUBRICATOR PRESSURE TEST..... - 23 -

IMPRESSION BLOCK PROCEDURE - 25 -

MAGNET USE PROCEDURE..... - 25 -

OFFICE SAFETY PROCEDURES..... - 26 -

PIPE WRENCH PROCEDURE - 29 -

PIPELINE BLOWDOWN..... - 30 -

PLUNGER RETRIEVAL PROCEDURE..... - 31 -

POURING SOCKET ROPE PROCEDURE - 32 -

USE OF PROPANE - 33 -

USE OF GAS CYLINDER..... - 33 -

PRESSURE UNIT PROCEDURE..... - 35 -

SAMPLE BAILER PROCEDURE..... - 38 -

SAND PUMP BAILER PROCEDURE..... - 40 -

SAND LINE INSPECTION PROCEDURE..... - 43 -

SLIP & CUT SAND LINE PROCEDURE - 44 -

SIDE ENTRY PROCEDURE - TOOL RETRIEVAL / COIL CLEAN OUT..... - 44 -



COIL CLEAN OUT – SIDE ENTRY - 45 -

SWABBING PROCEDURE - GENERAL..... - 51 -

 CHANGING SWAB CUPS..... - 52 -

 DERRICK RAISING / LOWERING..... - 53 -

SWABBING PROCEDURE – FRACK WELLS - 60 -

 DERRICK RAISING / LOWERING..... - 61 -

SWABBING PROCEDURE – HIGH PRESSURE & CRITICAL WELLS - 65 -

SWABBING PROCEDURE – TUBING WELLS WITH ≤ 90 °C DOWNHOLE TEMPERATURE - 67 -

SWABBING PROCEDURE – LOW PRESSURE GAS WELLS WITH NO DEMCO / MASTER VALVE..... - 68 -

SWABBING PROCEDURE – SLANT WELL - 69 -

TANK TRUCK PROCEDURE - GENERAL - 71 -

 HOSE REEL PROCEDURE..... - 72 -

 HOSE REEL OPERATIONAL SEQUENCE FOR TANK # 15 (GREEN UNIT)..... - 74 -

 LOADING / UNLOADING TANK TRUCK PROCEDURE..... - 75 -

 TANK TRUCK WITH PUMP PROCEDURE..... - 76 -

 SPEC 2 TANK TRUCK WITH PUMP PROCEDURE - 76 -

 PREPARATION OF TANK TRUCKS PROCEDURE..... - 77 -

TOOL RETRIEVAL / WIRE ROPE (STUCK IN WELL PROCEDURE)..... - 78 -

USING HAND TOOLS AT HEIGHTS PROCEDURE - 79 -

WASH BAY PROCEDURE - 80 -

WAX KNIFE PROCEDURE - 82 -

WELDING EQUIPMENT PROCEDURE..... - 84 -

WR (WIRELINE RETRIEVAL) PLUG PROCEDURE..... - 85 -

WILDLIFE PROCEDURES..... - 86 -

 RATTLE SNAKES..... - 86 -

 CERVIDAE MAMMALS (DEER FAMILY) - 87 -

 RODENTS - 88 -

 INSECTS - 88 -

FIRE AND EXPLOSION HAZARD MANAGEMENT - 90 -

 TYPES OF CONTROLS, CONTROL PRIORITIES AND METHODS OF CONTROL..... - 94 -

 FIRE & EXPLOSION INCIDENTS & FOLLOW UP..... - 97 -

PROCEDURES

REVIEWED MAY 2026

*Please note the formatting change to this manual. To comply with our **Environmental Policy** and conserve paper used in this manual – all direct quotes from the Occupational Health & Safety Act, Regulation & Code have been removed. However, some sections may reference this publication.*

It should also be noted that Element 3 no longer has one policy or procedure per page but has been reformatted to conserve paper used. Ensure you use the table of contents to quickly find the section you are looking for.



GENERAL PROCEDURES GUIDELINES

- Employees must start each day by being on time and well rested for the days' work. Refer to the **FATIGUE MANAGEMENT POLICY**
- All employees must have in their possession all required oilfield tickets and specific oil company orientation certificates.
- Follow ALL **PERSONAL PROTECTIVE EQUIPMENT POLICIES**
- A pre-trip inspection must be performed on the swab rig and documented in the Drivers' Daily Logbook.
- Ensure all safety devices are in place and operable (spill kits, windssocks, etc.)
- Repair any minor deficiencies and document. Function test motor kill(s) and document. Contact the Field Supervisor or General Manager if the forthcoming job could be compromised.
- Bump test personal monitors and record results.
- Crew must follow **EQUIPMENT MAINTENANCE PROCEDURE**
- while travelling to job and follow all directions given for permits and agreements for road use.
- When approaching lease, observe wind directions, overhead power lines, other services or activity taking place on location and always read and obey signage.
- Park on side of entrance to lease and ensure all employees are wearing proper PPE. Display appropriate Swab Master Ltd. warning sign at the lease entrance for the safety of others who may enter the lease unaware of the dangers associated with the process of swabbing.
- Walk into location taking notice of ground conditions, particularly areas where you may be required to drive the equipment and approach oil company representative for further direction.
- Complete a Pre-Job Safety Meeting to identify all hazards and implement appropriate controls.
- Always use a spotter when backing up equipment
- DO NOT block-off lease entrance/exit with line pipe or flow line hose for obvious reasons

RESPONSIBILITIES

All responsibilities for each level of employee are identified in Element 2 of this Safety Manual. The following responsibilities are general guides with respect to completing tasks and procedures.

RIG SUPERVISORS

- Ensure the employees are under direct supervision and follow guidelines
- Complete each procedure / task as directed in accordance with protocols
- Ensure employees have adequate training for the task
- Communicate with the Client Representative or Swab Master Ltd. Senior Manager if the job could become compromised.
- Ensure all personnel are equipped with appropriate Personal Protective Equipment
- Follow and enforce company policies and regulations
- Lead by example

RIG ASSISTANTS

- Understand and adhere to policies and procedures
- Take direction from the Supervisor
- Ensure equipment is inspected and maintained before each task
- Exercise your "right to refuse" if you feel you have not received adequate training for any task
- Follow all company policies and regulations
- Ensure you are equipped with all appropriate Personal Protective Equipment



BACKUP PROCEDURE

APPLICATION

To safely back up motorized equipment.

HAZARDS & CONTROLS

PRESSURE	Procedure Training; Communication; Caution
EXTREME WEATHER (COLD & HEAT)	Communication; Pre-Job Safety Meeting; Weather Watch; Caution; Emergency Response Plan;
PINCH POINTS	Pre-Job Safety Meeting; Communication; Caution

GUIDELINES & INFORMATION

The major reason for incident/accident collisions is caused from vehicles backing up. “Blind Spots” are fault for articles unseen is probably the biggest aspect of collisions. A consistent or routine procedure will solve the problems of back up incidences. The topic of safe back up procedures should be educated through training, safety meetings and communication with the driver and spotter before a task.

- All windows must be kept clear and no obstructions,
- Ensure a “spotter” is available,
- Ensure equipment is maintained to schedules or usage.

PROCEDURE

1. Review the Pre-Job Safety Meeting to confirm hazards are appropriately controlled and the scope of work has not changed.
2. Circle your unit before attempting to back up. This reassures you what objects and the distance for a safe task
3. In construction or lease areas, ensure that a spotter is available. The spotter is to be positioned at rear of vehicle on driver’s side and remain in operators view throughout the operation.
4. Ensure the hand signals and directions are coordinated and understood between the driver and spotter
5. One (1) blast of the horn. This allows anyone in the area knowledge of your task
6. If your unit is equipped, ensure the backup alarm is working
7. If backing up with a rig or tank truck, ensure your spotter is always visible. Stop the unit when the spotter disappears from sight of mirrors,
8. If backing up Alone: use a “cone procedure” using the safety orange cones. One cone must be placed on driver’s side of vehicle at the approximate stopping point estimating the total length of vehicle. Back up until the driver's door is next to the cone. The rear of the vehicle should be at the desired stopping point. If you lose sight of the stopping point cone, STOP your vehicle, re-evaluate your backing area, and reposition the cone. Nighttime tip: Place a flashlight in the final stopping point cone to better visualize your final stopping point.

***** STAY ALERT – STAY ALIVE *****



BLIND BOX PROCEDURE

APPLICATION

A simple slickline tool designed to jar an obstruction down the tubing string and the preferred tool run on the bottom of the toolstring for tagging fill or fluid.

HAZARDS & CONTROLS

PRESSURE	Procedure Training; Pre-Job Safety Meeting; Caution; PPE
PINCH POINTS	Procedure Training; Pre-Job Safety Meeting; Caution; PPE
H2S	H2S Training; Procedure Training; Pre-Job Safety Meeting; Caution; PPE – Personal Gas Monitor, Respiratory Protection
FIRE & EXPLOSION	Procedure Training; Pre-Job Safety Meeting; Caution; PPE
CHEMICALS	WHMIS Training; Procedure Training; MSDS; Pre-Job Safety Meeting; Caution; PPE
EXTREME WEATHER (COLD & HEAT)	Pre-Job Safety Meeting; Communication; Weather Watch; Caution; PPE
MUSCULOSKELETAL INJURY	Pre-Job Safety Meeting; Procedure Training; Caution; Frequent Breaks, Stretching

GUIDELINES & INFORMATION

A blind box is used to dislodge or push tools or equipment down the wellbore. It consists of a solid bar with a flat hardened bottom end and an industry standard thread connection and fishing neck on top. It is generally of heavy construction and is hardened to reduce damage when jarring is required. Blind boxes are also used as a means of breaking Sand line / wireline at the rope socket.

- The blind box run is made into the well very slowly, while keeping close watch on the weight indicator.
- Assess the tubing content (fluid or gas) when choosing toolstring weight.
- Choose the correct blind box O.D. to cover the area of obstruction.
- Ensure the blind box is not too large to pass any in-hole restrictions that may be encountered
- Make sure that when using a blind box, you do not plug off the hole you are jarring in and that it does not have to close of a tolerance around it.
- When the blind box is run on the end of a toolstring to cut wire form a rope socket of lost wire and tools, be sure the O.D. of the blind box will be sufficient.
- For heavy downward jarring of obstructions, weight bars should be run BELOW your spang jars to prevent the spangs from bellling-out.

Blind Box Diagram on the next page...

Blind Box



1. toolstring equipment

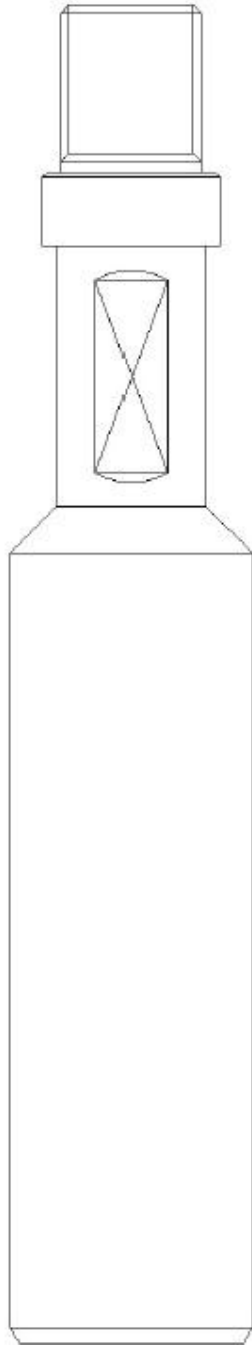

PURPOSE

Used to deliver downward jarring blows.

DESCRIPTION

For heavy downward jarring to move obstructions downhole, add sufficient stem weight.

Choose the correct blind box O.D. to cover the area of obstruction, ensuring the blind box is not too large to pass any restrictions that maybe encountered.

When the blind box is ran on the end of a toolstring to cut wire from a rope socket of lost wire and tools be sure the O.D. of the blind box will be sufficient.

Max O.D.	Fishneck Size	Thread Connection	Part Number
.75"	.75"	0.50"-13 NC	0101BB07501
1.25"	1.00"	0.625"-11 NC	0101BB12501
1.625"	1.375"	0.938"-10 UN	0101BB16201
2.00"	1.375"	0.938"-10 UN	0101BB20001
3.00"	1.75"	1.062"-10 UN	0101BB30001
4.00"	2.31"	1.062"-10 UN	0101BB40001
5.00"	2.31"	1.062"-10 UN	0101BB50001
6.00"	2.31"	1.062"-10 UN	0101BB60001



BOTTOMHOLE BUMPER SPRING PROCEDURE

APPLICATION

Setting and pulling Bottomhole Bumper Springs

HAZARDS & CONTROLS

Refer to **SWABBING PROCEDURE – GENERAL** for a complete list of hazards, while paying special attention to:

PRESSURE	Procedure Training; Pre-Job Safety Meeting; Equipment Inspections; Caution; PPE
H2S	H2S Training; Pre-Job Safety Meeting; Emergency Response Plan; PPE – Respiratory protection, Personal Gas Monitor
FIRE & EXPLOSION	Training; Follow Procedure Guidelines; Pre-Job Safety Meeting; Emergency Response Plan; PPE

GUIDELINES & INFORMATION

Bottomhole Bumper Springs protect the plunger and downhole tubing equipment from damage by absorbing the impact of the plunger when it lands at the bottom of the well. The bottomhole assembly may contain one or a combination of a plunger stop, bumper spring, standing valve, and strainer nipple. If tubing has not yet been run in the well, the bottomhole assembly can be run in place from the surface. If the tubing is in place, the bottomhole assembly can be dropped from surface, or if the well is dead, it can be installed using a swab rig with the appropriate running tool attached to the toolstring.

PROCEDURE

1. Review the Pre-Job Safety Meeting to confirm hazards are appropriately controlled and the scope of work has not changed.
2. Review, discuss and understand the following well data and job details:
 - well depth (PBSD)
 - depth of bottomhole bumper spring assembly
 - type of fluid in the tubing and annulus
 - anticipated fluid level
 - initial and anticipated well pressures
 - sand or wax problems in the past
 - type of retrieval tool to be used ensuring the lubricator is the correct length to accommodate the toolstring and bottomhole bumper spring assembly

Continually monitor both casing and tubing pressures for the remainder of this procedure.

3. Attach a full drift gauge ring to the tool string that shall be ran to determine if the tubing is clean and free of any obstruction that may hinder the running of the retrieval tool and to confirm the specified set depth of the bumper spring.
4. Run tools slowly into the hole documenting any tight spots, restrictions, fluid level and nipple depth.
5. Pull out from the hole slowly documenting any tight spots and restrictions.
6. If it's been established that the tubing is clear and you were able to reach the bumper spring, remove the gauge ring and attach adequate jars and the appropriate retrieval tool to unseat the bumper spring assembly. A jar up (to shear) retrieval tool should be used, as it can be extremely difficult to shear off jarring down on a spring for obvious reasons, if you need to release from the fish.
7. When the bumper spring has been unseated, pull out from the hole slowly to avoid creating a swabbing action which could possibly cause the well to come back to life which could result in being unable to carry forward with any additional work desired such as tagging for fill (PBSD), running a nipple brush, broaching sections of the tubing or most importantly, for setting the bumper spring.

Setting the Bottomhole Bumper Spring assembly:

1. Typically, the oil company representative will examine the bumper spring assembly for damage to the fishneck, spring, ball, and seat (if equipped with a standing valve), and the seat-cups prior to installation.
2. Use a jar down (to shear) retrieval tool attached to a set of spang jars and desired weight bars to run the bottomhole assembly back into the well. The retrieval tool should be pinned with a very light brass pin or ½ pin which will easily shear off when the bottomhole assembly tags fluid while running back into the well.
3. Running the assembly in the well at a constant speed of around 100 metres/min should provide sufficient impact when tagging the fluid to shear off the fish.
4. Continue running the toolstring in at a reduced speed through the fluid. Ideally the bumper spring assembly will reach the cup-seat ahead of the toolstring, therefore allowing you to firmly land on the assembly when you reach the set depth. This will aide in seating the cups properly.
5. Confirm that the assembly is detached from the retrieval tool by slowly pulling upward while monitoring the weight indicator. Once confirmed, pick up a few metres and land firmly on the assembly a couple more times to ensure proper seating of the cups.
6. Pull out of the hole.
7. The well can now be swabbed as needed.
8. Rig off the well.
9. If directed, deploy the plunger, or assemble the wellhead and secure the well.



BRAKE ADJUSTMENT PROCEDURE

APPLICATION

To adjust air brakes on applicable units

HAZARDS & CONTROLS

EYE INJURY	Procedure Training; Follow Procedure Guidelines; Caution; PPE – Protective Eye Wear
PRESSURE	Procedure Training; Caution; Communication; PPE – Hard Hat
PINCH POINTS	Procedure Training; Caution; PPE – Impact Gloves, Steel Toes, Hard Hat
SLIP / TRIP / FALL	Pre-Job Safety Meeting; Caution; PPE – Slip Resistant Steel Toes or Ice Grips
LIGHTING	Pre-Job Safety meeting; Lighting Equipment
EXTREME WEATHER (COLD & HEAT)	Pre-Job Safety Meeting; Communication; Caution; Weather Watch; PPE – Coveralls, Gloves

GUIDELINES & INFORMATION

According to the legislated acts, brake adjustments must be completed on a regular basis. The slack adjusters are only allowed a maximum distance of a 2" slack. Swab Master Ltd. allows only 1 ½" travel of the slack adjuster.

- Equipment, Slack adjuster wrench, Measuring instrument, Chock blocks, Light source, Wire brush.

PROCEDURE

1. Secure vehicle and ensure the vehicle is on a flat of surface as possible.
2. Chock the wheels by placing blocks in front and behind the wheel,
3. Release maxi brakes on the unit,
4. Ensure the slack adjusters are free of grease, oil, and dirt,
5. Grasp the end of the slack adjuster where it is attached to the push rod. Pull toward you and measure the distance of travel or use a paint marker on the rod to make it easier.
6. Adjust the screw until the brake shoe is tight to drum. Back off the wrench ¼ to ½ turn. The wrench will turn easily when turning the proper direction. The adjuster will click as you turn the "S" cam to proper distance,
7. Tap the drum with your wrench to assure the shoes are clear of the drum or not dragging,
8. If you hear a dull "thug" the shoe is still connected,
9. If you hear a ring, the shoe is clear,
10. Measure the distance of travel again.
11. When finished, apply the brakes, and visualize the slack adjusters are at a 90o to the brake chamber,
12. If any deficiencies are noted, notify mechanic,
13. Remove chock blocks.

* NOTE: Keep a spare cage bolt in the cab or other dry space where it will not be misplaced

TRAINING

All employees are trained through air endorsement course through Alberta Transportation. Conduct refreshers through Safety meetings.



BROACHING TOOL PROCEDURE

APPLICATION

The Broaching Tool is used for resizing inside diameters of down-hole completion equipment. They may range in sizes from 1.660” to 4.50” in diameter and are most commonly made of one piece, a solid circular body with a series of offset cutting pads or cutting rings surrounding the entire circumference of the entire body length. The series of cutting edges diameters increase in size from the bottom to the top of the tool, usually in increments of 0.0001”, until reaching the maximum O.D. (outside diameter) on the top one or two series of cutting pads or cutting rings on the tool body.

HAZARDS & CONTROLS

Refer to **SWABBING PROCEDURE – GENERAL** for a complete list of hazards, while paying special attention to:

PRESSURE	Follow Procedure Guidelines; Pre-Job Safety Meeting; Procedure Training; Caution; PPE
FIRE & EXPLOSION	Pre-Job Safety Meeting; Training; Caution; PPE

PROCEDURE

1. Review the Pre-Job Safety Meeting to confirm hazards are appropriately controlled and the scope of work has not changed.
2. Review the following job details:
 - type of fluid in the tubing and annulus
 - anticipated fluid level
 - initial and anticipated well pressures
 - Check available well and down-hole data to ensure that the proper tool type and size are run.
 - Depth at which broaching is required
3. The tool string must have enough weight (sinker bars) to overcome the well pressure and friction pressure of the pack-off system (saver-head) and enough weight to effectively bore through the desired section of tubing or casing. At times, it may be necessary to work the affected sections with an undersized broach prior to running the broach tool with the required gauge (O.D.).
4. Record initial tubing and casing pressures and monitor pressures throughout broaching process
5. Attach broaching tool to tool string and run in hole at a controlled and constant speed to the desired depth.
NOTE: The flowline should be kept closed to help maintain well control.
6. Proceed with broaching requiring section(s)
7. Work the section(s) of tubing or casing as needed or as directed by the client representative.
8. It is important to only stroke down once, maximum twice before pulling up and freeing tool string.



CATADYNE HEATER LIGHTING & SHUT-DOWN PROCEDURE

APPLICATION

To safely start and shut-down Catadyne Heater

HAZARDS & CONTROLS

FIRE & EXPLOSION	Training; Pre-Job Safety Meeting; Emergency Response Plan; Check LEL and Portable Monitors; Do not operate heater in an explosive atmosphere; PPE
OXYGEN DEFICIENCY	Pre-Job Safety Meeting, Confined Space Pre-Entry Assessment; Gas Detection Procedure; PPE – Personal Gas Monitor, Respiratory Protection
HOT SURFACES	Pre-Job Safety Meeting; Caution; PPE

GUIDELINES & INFORMATION

Lighting heaters to prepare for cold weather to assist with reducing freeze-offs and maintain proper equipment operations during winter months. Turning Catadyne heaters off in spring to reduce unnecessary heat.

At no time should the start button be tied down or safety device bypassed

Locate proper battery connections on truck in vehicle owner's manual.

PROCEDURE

1. Ensure an explosive atmosphere is not present. Verify by using a calibrated gas monitor and record readings each time.
2. Inspect heater pad for damage or deterioration; look for tears, punctures or damage that may have occurred from external sources.
3. Inspect the vent system inside and outside of the building for integrity and ensuring that it is not plugged. Ensure the piping is intact and the vent hood is secure
4. Turn on power to electrical elements. Power supply may come from a hard-wired supply or be hooked up to the battery in your truck. Truck must remain 7.5 metres from hazardous area. Connect to the factory designed positive and negative charging points.
5. Turn on fuel gas supply
6. Rotate thermostatic temperature controller dial completely clockwise - this is the fully open position.
7. Wait 15 minutes
 - **NOTE: if using portable starter cables, use the procedure below:**
 - a. Inspect portable start cable for integrity. Cables showing signs of wear or damage must be repaired prior to use
 - b. Make twist lock connection to heater at the building
 - c. Make power connection to wither power studs (if equipped) or battery posts (on vehicle)
8. Depress reset button on top of the 100% safety shut-off valve. The button should return to its original position and internally open the valve to allow gas to flow to the heater. If the shut-off valve does not satisfy, leave power on an additional 5 minutes, and retry step 5. At no time should the start button be tied down or safety device bypassed.
9. Once the heater has been lit, disconnect power. When catalytic reaction is well established by either using a switch or removing booster style cables from truck. **If using portable starter cables: disconnect cables from truck battery to power stud, disconnect twist lock connection.**
10. Set thermostatic control. Wait 30-60 minutes to turn heater down to make sure heater remains lit.

SHUT DOWN

1. Shut off fuel gas supply to heater
2. Ensure the Catadyne heater is no longer running before leaving location.



CAISSON ENTRY PROCEDURE

APPLICATION

To safely enter a below ground confined space and rig up a lubricator to swab a well. In >10 ppm H₂S application, no piping or process can be opened without utilizing a site-specific practice applicable to the task.

HAZARDS & CONTROLS

Refer to **SWABBING PROCEDURE – GENERAL** for a complete list of hazards, while paying special attention to:

FALL FROM HEIGHT	Fall Protection Training; Pre-Job Safety Meeting; Emergency Response Plan; PPE – Fall Protection
H ₂ S	H ₂ S Training; Pre-Job Safety Meeting; Communication; PPE – Respiratory Protection; Personal Gas Monitor
WILDLIFE	Reference Wildlife Procedures; Pre-Job Safety Meeting; Caution; PPE – Coveralls, Gloves
OXYGEN DEFICIENCY	Pre-Job Safety Meeting, Confined Space Pre-Entry Assessment; Gas Detection Procedure; PPE – Personal Gas Monitor, Respiratory Protection
LIMITED EGRESS	Pre-Job Safety Meeting; Confined Space Pre-Entry Assessment; Caution

GUIDELINES & INFORMATION

- Proper PPE, including 4-head gas monitor
- *Confined Space Pre-Entry Hazard Assessment Form* must be completed for Swab Master Ltd. Internal Operations
- Definition of a restricted space: “restricted space” means an enclosed or partially enclosed space, not designed, or intended for continuous human occupancy; that has a restricted, limited or impeded means of entry or exit because of its construction.

PROCEDURE

1. Complete a Pre-Job Safety Meeting to identify all hazards and implement appropriate controls.
2. Ensure Emergency Response Plan is in place
3. Approach caisson from upwind wearing personal monitor watching and listening for hazards such as holes, snakes, gas leaks, etc. Reference **WILDLIFE PROCEDURES**
4. Check around plywood covering for snakes and noting location.
5. Stomp on edge of ply board listening for the rattle of a snake.
6. Remove plywood with anything but your hands (pipe wrench, shovel) just enough to insert a gas monitor into the caisson from above to check the atmosphere using a dog leash and 4-head monitor.
7. If necessary, remove the plywood to ventilate and check the caisson atmosphere again. H₂S must be <10 ppm, LEL must be <10%, O₂ levels between 19.5% to 23% & CO must be <25ppm.
8. Check the metal grating making sure the hinges are on the brace and test the atmosphere, if the covering didn't have a location there is usually metal tag on the grating.
9. Open grating above ladder and well, WATCH YOUR FOOTING and take a good look for any wildlife in caisson.
10. You may find salamanders, frogs, mice, rabbits, weasels, snakes, and spiders living or dead, if you can, safely remove the threats and continue.
11. Using a spotter, back rig up to proper distance for a swab, ensuring jacks are not on caisson.
12. Gather necessary tools and proceed down the ladder keeping three-point contact.
13. Once you are in the caisson take well pressure and follow **SWABBING PROCEDURE – GENERAL**
14. Remain vigilant for changing conditions, continuous monitoring must be maintained and immediate egress if any values begin to rise.
15. When done swabbing and rigged off, replace grating properly ensuring hinges are on the brace and cover with plywood as you found it.



EQUIPMENT INSPECTION PROCEDURE

APPLICATION

To inspect any operational equipment for deficiency prior to use. This is a major function of preventing accidents, incidents, and near miss events.

HAZARDS & CONTROLS

PRESSURE	Training; Follow Procedure Guidelines; Pre-Job Safety Meeting; Machine Guards; Caution; PPE
EYE INJURY	Follow Procedure Guidelines; Procedure Training; Caution; PPE – Eye Protection
EXTREME WEATHER (COLD OR HEAT)	Pre-Job Safety Meeting; Weather Watch; Communication; Perform indoors if possible; PPE – Coveralls, Gloves
PINCH POINTS	Follow Procedure Guidelines; Machine Guards; Procedure Training; Caution; PPE
BURNS	Follow Procedure Guidelines; Allow equipment to cool down if necessary; Caution; PPE

GUIDELINES & INFORMATION

Refer to Section 4: On-Going Inspections, for more information on the process and frequency of inspections. Check that your proper PPE and equipment are worn and in good condition. Perform a walk-around to identify hazards before beginning any inspection.

DEFINITIONS

Fore-see-ability — could a reasonable person have foreseen that something could go wrong?

Preventability — was there an opportunity to prevent the injury or incident?

Control — who was the responsible person present who could have prevented the incident or accident.

PRE-TRIP INSPECTION

To be performed and documented by drivers daily.
 Repair minor deficiencies as necessary. Document repairs.
 If required, lock unit out and contact General Manager.
 Hand in daily to the office.

800 km inspection (performed if trip exceeds 800 km)

Performed and documented by drivers every trip exceeding 800 km.
 Complete an inspection using the pre-trip criteria.
 Document inspection.
 Hand in daily to the office.

POST-TRIP INSPECTION

Performed after each day and documented by drivers.
 Complete an inspection using the pre-trip criteria.
 Document inspection.
 Hand in daily to the office.

PRE-JOB – DAILY INSPECTION

Performed daily and documented by Rig Supervisor.
 Procedure is directed in accordance with protocol and pre job forms.
 Hand in daily to the office.

RIG INSPECTIONS - WEEKLY

Performed on a weekly base and documented by Rig Supervisor
 Procedure is directed in accordance with protocol.
 Hand in weekly to the office

EQUIPMENT MAINTENANCE PROCEDURE

APPLICATION

General maintenance on equipment. Regular maintenance is one of the first steps in preventing accidents and incidents.

HAZARDS & CONTROLS

PINCH POINTS	Procedure Training; Follow Procedure Guidelines; Pre-Job Safety Meeting; Caution; PPE
PRESSURE	Procedure Training; Follow Procedure Guidelines; Pre-Job Safety Meeting; Caution; PPE
CHEMICALS	WHMIS Training; Pre-Job Safety Meeting; MSDS; Caution; PPE
MUSCULOSKELETAL INJURY	Pre-Job Safety Meeting; Caution; Frequent Breaks; Stretching
EYE INJURY	Pre-Job Safety Meeting; Follow Procedure Guidelines; PPE – Eye Protection
SLIP / TRIP / FALL	Pre-Job Safety Meeting; Caution; PPE – Anti-Slip Steel Toes or Ice Grips
NOISE	Pre-Job Safety Meeting; Hearing Conservation Training; PPE – Hearing Protection
EXTREME WEATHER (COLD & HEAT)	Pre-Job Safety Meeting; Communication; Caution; Weather Watch; PPE

GENERAL INFORMATION

Ensure that any maintenance or repairs that are performed are tracked on an Opportunity Report.

SERVICING VEHICLES

1. Review the Pre-Job Safety Meeting to identify all hazards and implement appropriate controls.
2. Look completely around and under vehicle and check for brake pedal pressure before moving the vehicle.
3. Have all bystanders stay in a safe area until the driver has stopped the vehicle.
4. Park on level, hard surface to make repairs.
5. Chock and block wheels to prevent movement during servicing.
6. Ensure the hood is secure before beginning work underneath.
7. Inspect a running engine with extreme caution. Avoid contact with fan blades and belts.
8. Avoid working around hot equipment such as exhaust pipes or manifolds. If such work is necessary, cover the hot equipment with some insulating protection to prevent getting burned.
9. Store the keys in a secure place when the vehicles are not in use or not attended.

DO NOT

- Do not use tools or service equipment without proper training.
- Do not use tools or service equipment without permission by your supervisor.
- Do not service vehicles while working alone.
- Do not allow smoking, open flames, or other sources of ignition in areas used for fuelling or servicing fuel systems. Warn others before servicing a fuel system.
- Do not rely on jacks, hoists, or hydraulic cylinders to hold the vehicle. Support equipment on proper size blocks or stands.
- Do not use compressed air to remove dust from equipment, work surfaces, or from clothing.
- Do Not perform welding repairs to a vehicle without disconnecting the battery.

TAKING VEHICLES FOR SERVICE REPAIR

If you find from your inspections or servicing that your vehicle needs to be repaired by an outside source, you must do the following:

- Contact management and advise them of the situation.



- Management will make arrangements for you or advise you where you are to make arrangements for repairs to your vehicle.
- Make sure all required documentation is in the vehicle.
- The service company should be apprised of repairs to be done prior to taking unit in.

GAS DETECTION PROCEDURE

APPLICATION

To determine if a hazardous combustible condition exists in the workplace.

HAZARDS & CONTROLS

FIRE & EXPLOSION	Procedure Training; Follow Procedure Guidelines; Pre-Job Safety Meeting; Caution; PPE
H2S	H2S Training; Follow Procedure Guidelines; Pre-Job Safety Meeting; Caution; PPE – Respiratory Protection, Personal Gas Monitor
EYE INJURY	Pre-Job Safety Meeting; Follow Procedure Guidelines; Caution; PPE – Eye Protection
PRESSURE	Procedure Training; Follow Procedure Guidelines; Pre-Job Safety Meeting; Caution; PPE
CHEMICALS	WHMIS Training; Procedure Training; MSDS; Caution; PPE

GUIDELINES & INFORMATION

It should be noted that combustible gas indicators calibrated for the LEL may not give any reading while sampling a vapor that is present in a very high concentration. Sufficient oxygen may not be present for the instrument to function properly. Negative readings may also be obtained when testing vessels containing high concentrations of gas. For this reason, it is good practice to measure the oxygen level prior to measuring the LEL.

If flammable gas is present, the objective should be to determine its source and take actions to either stop the source of gas or isolate it from any ignition sources. Always check that the emergency stop button is functioning properly.

Unless proved otherwise, flammable mixtures generally should be assumed to be present within 25 meters of production facilities. This assumption should be considered valid before:

- Confined Space and Restricted Space Entry
- Lighting fired equipment
- Introducing an ignition source into an area that may contain a flammable atmosphere

Refer to the in-house training module: Detection & Control of Fire & Explosion Hazards for information on how to properly calibrate and bump test your personal gas monitor. For additional information – refer to the USE OF GAS CYLINDER

PROCEDURE

The type of sampling required is dependent on the following:

- Work being performed
- Potential interferences from adjacent work areas
- Type of monitors in use,
- The ability of the operator to interpret the information after it is gathered, and
- The need for all the information.

In some cases, the workers and supervisors may determine a hazardous work site without using combustible monitors, for example – gas leaking from a valve.



If the employee decides that a combustible gas monitor is required to complete the initial hazard assessment or confirm that work procedures and policies are effective, he/she will have to carry out the following:

1. Function test (bump test) the monitor
2. Determine which sampling strategy you will use and select a start point for sampling
3. Perform the sampling in a structured manner to avoid missing a “hot” spot.
4. Record the readings
5. Interpret the information to inform workers whether the work site is safe or unsafe. For example:
 - Can work start or continue?
 - Are controls needed to reduce the concentration or exposure?
 - Should workers don SCBA or (SABA)
 - Has the concentration risen or fallen since the last sampling?
 - When is re-sampling required?

GAUGE RING PROCEDURE

APPLICATION

Used for gauging the drift size of the tubing I.D. When drifting a seating nipple, a gauge ring O.D. must be chosen allowing clearance to pass through the nipple bore without sticking.

HAZARDS & CONTROLS

FIRE & EXPLOSION	Procedure Training; Pre-Job Safety Meeting; Caution; PPE
PINCH POINTS	Pre-Job Safety Meeting; Follow Procedure Guidelines; Caution; PPE
PRESSURE	Pre-Job Safety Meeting; Follow Procedure Guidelines; Caution; PPE

GUIDELINES & INFORMATION

Common sizes that can be used:

O.D. Size	Drift Size
2-3/8	1.90
2-7/8	2.34
4-1/2	3.96
5-1/2	4.875

Used for clearing the build ups formed on the inside of tubing walls, such as:

- Cleaning light scale on the inside of tubing walls,
- Cleaning paraffin on the inside of tubing walls,
- Cleaning nipple bores,

PROCEDURE

1. Review the Pre-Job Safety Meeting to ensure all hazards are still identified and appropriate controls and emergency response plans are in place.
2. When the correct gauge ring O.D. is determined, connect it to the toolstring and run it to a known depth.
3. In most completions, the tubing will have a known restriction such as a seating nipple which will be the known run depth.
4. When cleaning tubing, clean short sections pulling up to clear the worked area. This ensures keeping the spang jars clean as debris can be worked up through the fluted openings.
5. When tight spots are encountered a few moderate downward jars may work the gauge ring through.
6. If this does not work pull the toolstring to the surface and remove gauge ring. Discuss with oil company representative an alternate method to rid the tight spot from the tubing.



GENERAL DRIVING & TRAVEL PROCEDURES

THE TRAVEL PROCEDURE IS FOR THE DRIVING OF PICK UPS, RIGS, TANK TRUCKS, AND ALL other company vehicles, also including personal vehicles during the time of working hours. All Government rules / regulations must be followed. Refer to Section 11 in the safety manual for in depth details on driving and travel rules and regulations.

Workers are to read and understand *Element 11 Commercial Transportation safety program*

- Only authorized personnel may operate any company vehicle(s).
- Make sure you arrive at the shop so that enough time is given for you to perform your tasks in a safe manner.
- Company policies prohibit any towing or pulling of any personal vehicles or equipment.
- Be prepared and fit for work, notify your supervisor ASAP if you are not. There will be no toleration of being under the influence of alcohol, illegal drugs, or being ill or fatigued.
- Workers must never operate motor vehicles and/or heavy equipment while excessively fatigued.
- Do NOT operate vehicle if taking over the counter medication or a prescription that impairs your ability to drive.
- Ensure that you have all equipment and paperwork for the day's job(s). Check your emergency equipment including flares, first aid, fire extinguisher (water and munchies for extreme weather)
- All vehicles must have a walk around safety check and pre trips done before every use.
- All driver logbooks are to be filled out and followed. (pre-trip and post trip) Any problems or repairs that need to be done that you notice throughout the day need to be reported and fixed before the next use of that vehicle.
- NO SMOKING while fueling a vehicle.
- Distracted driving is strictly prohibited. Refer to <https://www.alberta.ca/distracted-driving.aspx> for extended information
- All legal information must be at hand including drivers' licence, insurance, registrations, and permits for heavy trucks, and commercial licensing equipment, flares, first aid, fire extinguisher.
- Travel of highways, gravel roads, and lease roads are to be traveled upon with the upmost respect of the rules of the road. This means take into consideration:
 - Check and note road conditions and be prepared for emergencies (ice, wind, snow, rain, mud).
 - Visibility (dust, night, sun, fog,)
 - Other drivers, farmers, and wildlife should be treated with respect, no tailgating or dusting out farmyard or animals.

SAFE VEHICLE RECOVERY & TOWING

At times a vehicle may become stuck in snow or mud or may have to be removed from a high traffic area. Stop and consider the task at hand and assess the hazards prior to considering the recovery option. If you have any questions or doubts, it is best to rely on a towing service. This part of the policy is ONLY applicable when the stuck vehicle can assist with the recovery and will be fully capable of driving once pulled out.

REMEMBER: If at any point in the process you have any safety concerns whatsoever or concerns about potential damage to either vehicle - stop and call a certified tow truck.

Consider the following checklist prior to deciding to perform a vehicle recovery. If the answer is NO for any of these questions - call the professionals.

1. Do both parties have permission from their respective companies to perform a vehicle recovery?
2. Have you checked and considered the gross vehicle weights (including loads) of both vehicles?
3. Is the total weight of the recovery vehicle equal or greater than the weight of the stuck vehicle?
4. Do you have a recovery strap that has a minimum breaking strength that is 2-3 times the total weight of the stuck vehicle?
5. Is the recovery strap in good working condition?



6. Do you have an appropriate attachment point on both vehicles?
7. Can you line up the recovery vehicle with the stuck vehicle?
8. Is the towing route free of any obstacles or hazards?
9. Have you set up the necessary traffic control system?
10. Do both drivers understand the hazards of a recovery attempt, especially the deadly danger of recoil should any components fail?
11. Have you taken the time to consider any other possible hazards presented by the situation?

Identify the terrain - if the vehicle is stuck in heavy mud or on a steep incline, remember that this will add weight and may be too much for the towing straps being used. If the recovery is being completed on a roadway or other high-traffic area, you must implement a traffic warning or control system (example: cones or flares).

Ensure that you have the right equipment. The straps should be at least 6 metres (20 feet) in length - preferably with loops instead of hooks and in good condition. Inspect the straps for wear and tear. Using hooked tow straps can be extremely hazardous if they snap off - they can become like a projectile missile. Ensure that the strap has a minimum breaking strength that is 2 to 3 times the total weight of the stuck vehicle.

Check both vehicle weights and add the weight of any loads either vehicle is carrying. The vehicle doing the pulling must be of equal or, ideally, greater weight than the vehicle that is being pulled.

Ensure any tow hooks, hitch receivers or shackles used are rated to loads that exceed the recovery strap minimum breaking strength. In the event of excessive loads, the strap should always be the weakest link and snap first.

Clear out as much mud, sand or snow from under the stuck vehicle as possible and in front of the tires in the direction of the pull. Position the pulling vehicle in line with the stuck vehicle - with the pulling vehicle facing forward; the stuck vehicle being pulled from the front (preferably) or the back. You should be with 10 degrees of a straight line - side loading can lead to serious vehicle damage. You need to be sure you have a clear path straight forward free of any obstacles that is at least the length of the strap and the stuck vehicle.

Drape a heavy coat or blanket over the middle of the strap to dampen any backlash if it snaps or releases. Agree on a plan and communication signals between the two drivers. Ensure all bystanders are at least 2 times the length of the recovery strap to the side of the vehicles. Both the strap and the vehicles lurching forward suddenly present a hazard.

The pulling vehicle should accelerate slowly to build tension in the strap and provide a sustained pull. Once the slack is taken up, the stuck vehicle should also apply acceleration in low gear to assist the pulling vehicle. Both vehicles should try NOT to spin their tires. Steady momentum is most effective - never resort to jerking or take a long run and jerk. Maintain tension throughout the pull, do not allow slack to develop in the strap at any point. After three attempts to pull the vehicle loose - it is time to call a tow truck.

Do not remove the straps until both vehicles are fully stopped and secured. Make sure to clean and dry out the straps after use as dirt and moisture can weaken the straps.

*****Absolutely no littering.**

There is never an excuse for breaking the rules of the road such as speeding because you didn't give yourself enough time or take into consideration the road conditions. We want safety to be the first thing on our minds from the start of day and throughout. Company policies prohibit use of a cell phone, eating, or distractions such as music, books, personal matters, or maps during driving. If you need to do any of the above, pull off the road with safety precautions in mind. Seat Belts must always be worn!

Make sure there are no loose items in the passenger area that could cause damage to any person (s) in the cab of the vehicle. All these items must be secure. All trucks are to have a secure load. Everything must be tied down or covered. There is no toleration for loose loads or the loss of any equipment due to negligence.

Follow all the directions/permits given by the oil field company to and from the lease.

When a company job is to take more than one day or if travel time is over the recommended legal number of hours, a pre-planned route is to be done. (This means that a hotel or a place to stay must be booked or planned before leaving for that job.)



Always try to park your vehicle so you can move forward when leaving an area, avoid backing up if possible - follow Backup procedure if you have to backup. When leaving vehicle or equipment make sure it is in a safe and allowed place. Company policies prohibit any towing or pulling of any vehicles or equipment. As an employer it is our responsibility to take every precaution reasonable to protect our employees. As a worker you are responsible to work safely and use equipment (including your vehicle) in a safe manner.

HARASSMENT & VIOLENCE PROCEDURES

APPLICATION

As per Part 27 of the Occupational Health and Safety Code, section 389 - "Violence and harassment are considered hazards for the purposes of Part 2" (Part 2 being Hazard Assessment, Elimination and Control).

Swab Master Ltd. believes that all our employees and clients have the right to work in an environment that is free from all forms of psychological hazards such as harassment and violence.

HAZARDS & CONTROLS

WORKING ALONE	Follow Communications & Work Alone Policy; Office Safety Procedures; Caution
DEALING WITH CLIENTS	Use respect approach; Follow De-Escalating an Angry Person procedure
SHIFT WORK	Ensure sites are well lit; Do not go into unknown areas alone; Caution
HUMAN RESOURCES	Follow Office Safety Procedures; Follow De-Escalating an Angry Person Procedure; Caution

CONTROL METHODS

While it is impossible to control the main component of this type of hazard, people; there are some measures that can be taken to reduce or eliminate the risk of violence or harassment. Some effective control methods to use at our company include, but are not limited to:

1. using electronic surveillance while having signs indicating this
2. using locks or having physical barriers like high counters to separate visitors from workers
3. keeping workspaces, exits and parking areas clear and well lit.
4. limit the number of exits / entrances to buildings
5. post emergency numbers in plain view of everyone
6. set up worker-friendly reporting procedures and train workers to follow them
7. include harassment and violence prevention training in the orientation of new employees
8. review harassment and violence prevention methods regularly with all staff
9. have communications plan with specific call-in times for field employees
10. ensure violence is included in emergency response planning

11. train workers on how to identify signs of escalating behaviour and techniques on how to defuse a potentially violent situation - but ensure they understand **NEVER** to put themselves in harm's way.

PROCEDURES

Swab Master Ltd. is committed to protecting the physical, psychological, and social well being and safety of its employees and clients and will work to eliminate or control the hazards of harassment and violence. Information



regarding such hazards will be made available to all employees and is included in the hazard assessments done for each position listed in Element 2 of this manual.

The company encourages all persons to promptly report incidents and will suggest ways to reduce or eliminate risks. No employees will experience any reprisals because of reporting harassment or violence. An employee who believes they are being subjected to harassment is encouraged to make clearly and firmly known to the harasser that the harassment is objectionable and must stop.

Where circumstances prevent an employee from acting, or there is threat of violence, or the employee feels unsafe doing so, or the action taken is unsuccessful, the employee may report the alleged harassment to one of the following persons designated by our company to receive these complaints:

<i>Hong Zhong Guo</i>	<i>Operations Manager/Owner</i>	<i>403-409-9577</i>
<i>Shawn Gleisner</i>	<i>Assistant Operations Manager</i>	<i>403-376-4074</i>

If immediate assistance is required, where none of the above listed individuals are available, and the employee feels unsafe in the current situation - they must try to get themselves to a safe location and contact the RCMP.

Reporting harassment or threats of violence shall be always managed in a serious manner. All employees, supervisors and management are expected to always follow this policy and report all incidents in the workplace. All incidents should be reported in the same fashion as other events, using an Incident / Near Miss form. Employees who report incidents may also request to do so confidentially. Such requests will be honoured to the degree legally allowable. Any employee who is uncomfortable reporting incidents of harassment or violence in person may do so on our website @ www.swabmaster.com under the "NEWS" section of the Employee Resources Page.

Swab Master Ltd. will follow up on all reports of harassment or violence with a documented investigation focusing on identifying alternative ways of preventing future events. The company will inform all parties involved in the investigation of its findings, apply disciplinary action where needed and, recommend any further corrective actions to be addressed regarding the incident.

All employees reporting incidents of harassment, violence or threats of violence will be directed to seek medical attention from a treatment provider of their choice. The office has a listing of local practitioners who deal with psychological workplace incidents.

Swab Master Ltd. will review these procedures with the consultation of the Safety Coordinator and affected workers when:

- a) an incident of harassment or violence has been reported
- b) every three years
- c) upon recommendation from the Safety Coordinator or an affected employee

H2S TRAILER PROCEDURE

APPLICATION

The Lubricator Off-gas Control (LOC) Unit is designed to collect, control, and treat H2S and other off-gases from the lubricator saver-head drain line. These gases are the result of gas, and gas saturated fluid, caught between the first



and second stripper rubbers in the saver-head. This gas exits the saver-head through the saver-head drain line, and if not treated, will create an objectionable odor, and potential safety hazard.

HAZARDS & CONTROLS

PRESSURE	Procedure Training; Follow Procedure Guidelines; Pre-Job Safety Meeting; Caution; PPE
H2S	H2S Training; Procedure Training; Follow Procedure Guidelines; Pre-Job Safety Meeting; Caution; PPE – Respiratory Protection, Personal Gas Monitor
FIRE & EXPOSITION	Procedure Training; Pre-Job Safety Meeting; Caution; PPE (*Note: Heater + Gas = potential explosion)
BURNS	Procedure Training; Pre-Job Safety Meeting; Caution; PPE

PREPARING FOR TOWING

1. Walk around trailer:
 - check tires
 - ensure that skid is secured
 - ensure that all hoses are disconnected
2. Have spotter direct vehicle back to hookup to trailer.
3. Drop the Penndel hitch ring of the trailer onto the Penndel hitch hook on the vehicle.
4. Ensure that the Penndel hitch latch is down, the latch is locked, and the safety pin is in the latch.
5. Hook up safety chains.
6. Plug in lights.
7. Ensure that all trailer lights are working.
8. Remove choc blocks and stow blocks in toolbox on trailer.
9. Check brakes.
10. The LOC Unit is ready to tow.

PREPARING FOR OPERATIONS ON SITE

1. Complete a Pre-Job Safety Meeting to identify all hazards and implement appropriate controls.
2. Ensure Emergency Response Plan is in place.
3. Spot the trailer, using a spotter at all times.
4. Unhook the trailer, safety chains, and lights from the tow vehicle, and chock the trailer wheels.
5. Put the stairs on the LOC Unit down.
6. Connect saver-head drain hose to 1" inlet on the back of the LOC Unit.
7. Connect vent hose to outlet and turn on high level alarm.
8. Put up signs and safety cones.
9. Open inlet and outlet valves on the LOC Unit.
10. You are now ready to swab.

UNLOADING LOC UNIT WITH TANK TRUCK

1. Spot tank truck, using spotter at all times.
2. Hookup ground line to ground point on trailer.
3. Shut 1" valve on the saver head relief head and disconnect the hose so that it acts as a vent.
4. Hookup tank truck hose to unloading connection point on tank.
5. Open valve and begin unloading making sure that the tank has vent.
6. When finished unloading, disconnect tank truck and shut valve on outlet and put in cap.
7. Hook 1" line back up to the inlet and open 1" valve.



8. Continue swabbing.

UNLOADING USING AN AIR PUMP

Use the air pump on the LOC Unit when unloading to a tank that does not have a pump, or when you do not have enough suction hose to reach the tank from the LOC Unit. Using the LOC Unit air pump will allow you to use a discharge hose instead of a suction hose in the unloading process.

1. Shut 1" valve on Saber Head Relief Hose and disconnect 1" hose.
2. Put in fittings in tank to be filled.
3. Connect the 2" hose to tank and pump.
4. Connect airline to pump and rig air. Open valve at the outlet behind the pump.
5. Open air supply valve to pump to begin pumping and open the valve on the tank.

LIGHTING HEATER FOR COLD WEATHER OPERATIONS

1. Connect heater element power cable to rig, tank truck or pickup. Power connection is only required to start the heater, not to run.
2. Turn on propane bottle and open valve on regulator to supply gas to the heater.
3. Wait until the element gets hot and push button on orifice.
4. Disconnect power cables

HYDROSTATIC LUBRICATOR PRESSURE TEST

APPLICATION

To safely hold a steady pressure reading from a lubricator and all its threaded parts for 15 minutes without leaks.

HAZARDS & CONTROLS

PRESSURE	Procedure Training; Follow Procedure Guidelines; Pre-Job Safety Meeting; Caution; PPE
PINCH POINTS	Pre-Job Safety Meeting; Follow Procedure Guidelines; Caution; PPE
EYE INJURY	Pre-Job Safety Meeting; Caution; PPE – Eye Protection
MUSCULOSKELETAL INJURY	Procedure Training; Pre-Job Safety Meeting; Frequent Breaks; Stretching; Caution
FIRE & EXPLOSION	Procedure Training; Pre-Job Safety Meeting; Caution; PPE
SLIP / TRIP / FALL	Pre-Job Safety Meeting; Caution; PPE – Anti-Slip Steel Toes, Ice Grips
EXTREME WEATHER (COLD & HEAT)	Pre-Job Safety Meeting; Emergency Response Plan; Caution; Weather Watch; PPE
LIGHTING	Pre-Job Safety Meeting; Lighting Equipment; Caution

GUIDELINES & INFORMATION

Proper PPE, hazard assessment, good drainage, fittings secure and pointed in safe direction
Preparation: proper training, proper equipment, determine scope of work and practices

PROCEDURE

1. Complete a Pre-Job Safety Meeting to identify all hazards and implement appropriate controls.
2. Ensure Emergency Response Plan is in place
3. Secure lubricator on stands, tubs or blocks keeping the end to be filled higher (usually the top) and coil tubing entry pointing down.
4. Gather all fittings and tools to seal lubricator.
5. Correctly apply Teflon tape on threads.
6. Apply pipe dope on Teflon tape and hammer unions.
7. Tighten all fittings except the high end where test tree is to be installed into lubricator.



8. Using the highest point slowly fill lubricator with clean water.
9. When filled with water, Teflon tape and dope test tree then install and tighten (be sure to have two pressure gauges of equal range 0-5000 psi that have been calibrated).
10. Check connections on baker pump.
11. Slowly pump until air is purged from lubricator and test tree.
12. Ensure yourself and others are not standing in line of fire (in front of any plugs or valves).
13. Pump until both gauges read appropriate pressure and shut valve to pump.
14. Hold pressure for 15 minutes or required time safely inspecting welds and threads for leaks.
15. If both gauges have not changed after 15 minutes the test is good.
16. If pressure has dropped find the leak, stop it, and begin again.
17. Release pressure from pump by SLOWLY opening relief valve.
18. Disconnect baker pump fitting.
19. Bleed lubricator pressure by SLOWLY opening valve on the test tree that held baker pump.
20. Empty water out of lubricator in such a manner that it won't cause a hazard.
21. Document, report the test results, and obtain a stamped band for that lubricator.
22. Clean and put equipment back properly.

IMPRESSION BLOCK PROCEDURE

APPLICATION

Impression Blocks - The Impression Blocks provide a means of taking impressions of down hole blockages, obstructions, and tubular damage. Impression blocks can be made to any desired outside dimension. Refer to **GENERAL SWABBING PROCEDURE** for more guidelines.

HAZARDS & CONTROLS

FIRE & EXPLOSION	Procedure Training; Pre-Job Safety Meeting; Caution; PPE
PINCH POINTS	Pre-Job Safety Meeting; Caution; PPE
PRESSURE	Pre-Job Safety Meeting; Communication; Caution; PPE

PROCEDURE

1. Review the Pre-Job Safety meeting to ensure all hazards have still been identified and no new controls need to be implemented, or emergency response plans revised.
2. Review the following job details:
 - Reports on well
 - Depth of blockage or obstruction
 - Check available well and downhole data to ensure that the proper tool type and size are run.
3. Make sure bottom of impression block is clean, file if needed and then attach to tool-string.
4. Run into hole at a constant speed.
5. Before reaching target depth stop 20m above to let the tool-string settle out
6. Continue to obstruction in well, set down on obstruction gently.
7. Lift up on jars enough to open them apart, about 1 foot.
8. Jar down only once, if possible, to get a clear impression.
9. Come out of hole slowly
10. Remove block. Forward and / or discuss the results with the oil company representative.

MAGNET USE PROCEDURE

APPLICATION

To fish ferrous metallic debris from wellbore - magnet

HAZARDS & CONTROLS

PRESSURE	Procedure Training; Follow Procedure Guidelines; Caution; PPE
FIRE & EXPLOSION	Procedure Training; Pre-Job Safety Meeting; Caution; PPE
H2S	H2S Training; Procedure Training; Follow Procedure Guidelines; Emergency Response Plan; Caution; PPE – Personal Gas Monitor, Respiratory Protection
EYE INJURY	Pre-Job Safety Meeting; Follow Procedure Guidelines; Caution; PPE – Eye Protection
PINCH POINTS	Follow Procedure Guidelines; Pre-Job Safety Meeting; Caution; PPE
EXTREME WEATHER (COLD & HEAT)	Pre-Job Safety Meeting; Communication; Weather Watch; PPE

GUIDELINES & INFORMATION

The EBT RE Magnet is made up of two components: Housing & Magnet. The magnet is retained in a metallic housing with the face of the magnet slightly inset to avoid being damaged.

Precautions: Care should be taken not to jar or impact the magnet surface as cracking or breakage may occur. Care should also be taken not to place fingers or skin between magnet surface and any ferrous material, these magnets are very strong, and injury may occur.



PROCEDURES

1. Complete a Pre-Job Safety Meeting to identify all hazards and implement appropriate controls.
2. Ensure Emergency Response Plan is in place
3. Be sure to review the following job details:
 - Anticipated or maximum depth to run magnet
 - type of fluid in the tubing and annulus
 - anticipated fluid level
 - initial and anticipated well pressures
 - Check available well and downhole data to ensure that the proper tool type and size is run.
4. Record starting pressures
5. attach appropriate size magnet
6. Run into hole at a constant speed.
7. Stop above target and note weight indicator
8. Continue to target depth
9. Work magnet on and over obstruction to allow ferrous metallic debris from wellbore to attach to the magnet.
10. Come out of hole at a very slow rate of speed, monitoring weight closely.
11. Repeat process if necessary
12. Record all data.

OFFICE SAFETY PROCEDURES

APPLICATION

General office operating safety information. Always ensure you are familiar with your job description and hazard matrix from Element 2 in this safety manual.

HAZARDS & CONTROLS

MUSCULOSKELETAL INJURY	Ergonomic Workspace; Frequent Breaks; Stretching
LIGHTING	Ensure adequate lighting to prevent eye strain and headache
FATIGUE	Frequent Breaks; Stretching; Fatigue Management Awareness
HARASSMENT	Caution; Awareness of Threatening Behaviour; Comply to Work Alone Policy
MENTAL STRESS	Caution; Ask for Assistance
BIOLOGICAL HAZARDS	Awareness; Proper Handwashing; PPE (Field paperwork may be contaminated – wear gloves if necessary)
VIOLENCE	Caution; Awareness of Threatening Behaviour; Comply to Work Alone Policy
GLARE	Screen Cover; Turn screen away from sources of light; Frequent Breaks to rest the eyes

GUIDELINES & INFORMATION

- Drawers of desks and the file cabinets shall be kept closed when not being used
- Place file cabinets such that drawers do not obstruct aisles or walkways
- If working alone, follow the guidelines in the work alone policy. Lock the front door after hours or if you feel unsafe.
- Pull out only ONE drawer at a time to avoid tipping the file cabinet
- Keep aisles, walkways, and work area clear of obstacles and tripping hazards such as boxes or electrical cords.
- Open doors slowly to avoid striking anyone
- Use caution when walking around blind corners



- Faulty electrical cords and equipment must be removed from service and immediately repaired or discarded.
- Lock electrical equipment in the “off” position or disconnect from the power source before attempting to clean or adjust moving parts (i.e., unplug photocopier when removing jammed paper).
- Wear the appropriate personal protective equipment (i.e., goggles, gloves, aprons, etc.) when handling chemicals for photocopiers. Consult the material data safety sheet (MSDS) for the chemical information.
- Blades on paper cutters shall be kept in the closed position when not in use.
- Sharp pointed objects shall be kept in the front of desk drawers where they are visible, to prevent cuts to the hands.
- Be aware that computer workstations have a recommended ergonomic setup that should be maintained to minimize conditions such as poor posture, repetitive strain injuries, back and neck problems, and eyestrain.
- All personnel shall be made familiar with their local emergency evacuation procedures and routes.
- Never block fire extinguishers or emergency/fire exits.
- When storing objects on wall mounted shelving always store heavy objects on the bottom of the unit with progressively lighter materials at the upper levels. The shelves should not sag in the middle.

SUMMARY

It is important not to underestimate the potential hazards in an office. Use these guidelines to help you recognize hazards and reduce office accidents.

Emergency Response for Harassment / Violence in the Office

If you are working alone in the office area of the main location - it is wise to keep the front door locked at all times. This will allow you to screen the individuals you let into the area. If you can observe that someone is obviously very angry and aggressive - you can tell them to come back another time to voice their complaint or have them, call the office line to discuss - while letting them know you do not feel safe in their presence.

If the aggressor is already inside the office (for example, if the person becomes angry about something while inside the office - like a payroll dispute) there aren't many options for escape. In this case, use the following techniques to try and de-escalate the situation.

De-Escalating an Angry Person

Firstly, a caveat: People experience and express their anger in a lot of different ways. Some internalize by pouting or withdrawing. Some yell, scream, swear, or insult others. Obviously, the way to respond to different anger expressions will differ. The purpose of this policy is to discuss ways to deal with people who are verbally aggressive, insulting, or even threatening.

1. Ask yourself if the Anger is justified

Sometimes anger is perfectly reasonable, and it is always emotionally wise to consider the feelings of others during an interaction. You should ask yourself why the person is angry, what role you may have played, and if there is anything you can or should do to resolve the situation. It's important to note that a person can be justifiably angry yet express that anger in an unjustifiable way. For example, it is justifiable to be angry that you did not get paid on time, but it is not justified to harm another person because of that.

2. Stay Calm

One of the most important things you can do when someone is angry at us is to stay calm. By that, I mean to avoid yelling, swearing, or raising our voice. We may not feel calm in the situation, but we can still act steadily.



By speaking slowly and directly, and keeping our voice calm and soft, we are less likely to exacerbate a situation. People tend to match each other's volumes, pace, and general tone, so instead of meeting the angry person where he or she is at—and escalating the situation—try to de-escalate the situation by subtly encouraging them to lower their voice.

3. Avoid Character Assaults

A guaranteed way to escalate an angry situation is to attack the other person's character. Insulting them, or even saying things like, "You always do this," is likely to make things worse. Instead, focus on specific behaviors or feelings in the moment. Instead of saying, "You always yell at me when you're angry," say, "Please don't yell at me." Instead of saying, "You're so impatient," say, "Can you please be patient with me." Those may seem like subtle differences, but you don't want the person to feel attacked, as it will make them even more likely to lash out.

4. Know When to Disengage

In any exchange with an exceedingly angry person, there may come a point when you need to disengage from the situation. There are lots of reasons why this might be the smart thing to do: To stay safe, but also, and more commonly, because the situation is such that there is unlikely to be any positive resolution. The person may be so angry that a healthy, reasonable conversation simply can't be had at the time. If that's what is going on, the best thing to do might be to say, "Let's talk about this later when we're calm," and move on.

5. Stay Safe

Finally, but primarily, when you are dealing with an angry person, you must make sure you are safe. People can be angry without being physically aggressive, of course and an angry person is not necessarily a violent person; far from it. However, we need to know when people are angry, they may feel the urge to lash out, sometimes physically. If you don't feel safe, get away from the person. Period. If you absolutely must interact with someone who you feel threatened by, try not to be alone with the individual, and enter the situation with a plan to get yourself out safely if the need should arise.

If you are unable to calm the aggressor, you can try asking them once again to leave the area until they are calmer. Depending on the situation, you will have to question what your response should be. For example, if the antagonist is alone and becoming more and more irate, you can use the air horn on the desk. One LONG BLAST will alert anyone in the shop that you are in a dangerous situation and need assistance. This will likely bring the angry person back to awareness of the situation and they will calm down or leave. You may also say that you need to use the phone and call one of the managers that you know to be on site.

In other cases, they may become even angrier. In such cases, it is wise to lock yourself in the office manager's office and call the police. However, if the aggressor has a weapon of any sort - it would be best to remain as calm as possible and pacify their anger until they are able to calm down or you are able to contact someone for help. This would be the case as well if it is known that there is no one working in the shop to come to your aid.

The best response will depend on the situation and your ability to read it. The most important note to remember is not to mirror the feelings of the angry person. Stay calm and be patient enough to allow the person to settle down.

PIPE WRENCH PROCEDURE

APPLICATION

How to properly use a pipe wrench safely.

HAZARDS & CONTROLS

PRESSURE	Procedure Training; Pre-Job Safety Meeting; Caution; PPE
PINCH POINTS	Pre-Job Safety Meeting; Caution; PPE
EYE INJURY	Pre-Job Safety Meeting; Caution; PPE – Eye Protection
SLIP / TRIP / FALL	Pre-Job Safety Meeting; Caution; PPE – Anti-Slip Steel Toes; Ice Grips
MUSCULOSKELETAL INJURY	Procedure Training; Pre-Job Safety Meeting; Frequent Breaks; Stretching

GUIDELINES & INFORMATION

Pipe wrenches are used to tighten and loosen threaded pipes. A pipe wrench is an adjustable wrench — the top jaw moves up or down — and has toothed jaws for gripping onto pipe. The jaws on a pipe wrench are designed so that the top jaw (aka the hook jaw) rocks a little bit in the frame of the wrench. Whenever you apply forward pressure on the handle, the top and bottom jaws come closer together. Pipe wrenches come in different sizes and are measured by the length of the handle.

Always use the correct tool for the job.

- Wear safety glasses or goggles, or a face shield (with safety glasses or goggles), when necessary.
- Select a pipe wrench with sufficient capacity and leverage to do the job.
- Use a pipe wrench to turn or hold a pipe.
- Adjust the pipe wrench grip to maintain a gap between the back of the hook jaw and the pipe. This concentrates the pressure at the jaw teeth, producing the maximum gripping force. It also aids the ratcheting action.
- Inspect pipe wrenches periodically for worn or unsafe parts and replace them (e.g., check for worn threads on the adjustment ring and movable jaw).
- Keep pipe wrench teeth clean and sharp.
- Pull, rather than push on the pipe wrench handle.
- Maintain a proper stance with feet firmly placed to hold your balance.

Important Safety Tips

- Do not use snipes on aluminum pipe wrenches. If necessary, use of snipes is allowed on steel pipe wrenches, provided it is an engineered snipe.
- Do not use a pipe wrench as a hammer or strike a pipe wrench with a hammer.
- Do not use pipe wrenches on nuts and bolts.
- Never use a pipe wrench to bend, raise or lift a pipe.
- Snipes and/or wrenches must never be used to assist closing the master valve – see General Swabbing Procedure.

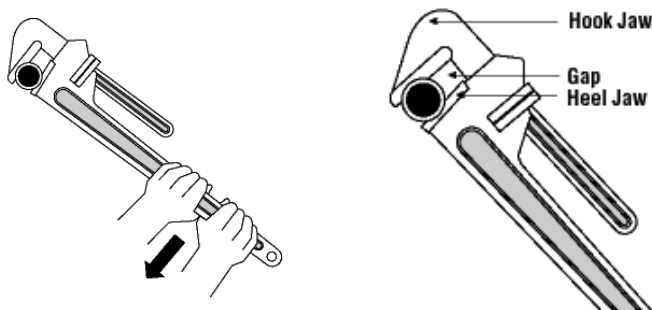



PIPELINE BLOWDOWN

APPLICATION

Cleaning a pipeline is often the simplest way to achieve greater production and at times is necessary due to complete blockage.

HAZARDS & CONTROLS

PRESSURE	Procedure Training; Pre-Job Safety Meeting; Caution; PPE
FIRE & EXPLOSION	Procedure Training; Pre-Job Safety Meeting; Caution; PPE
SLIP / TRIP / FALL	Pre-Job Safety Meeting; Caution; PPE – Anti-Slip Steel Toes, Ice Grips
NOISE	Procedure Training; Pre-Job Safety Meeting; Caution; PPE – Hearing Protection
H2S	H2S Training; Procedure Training; Pre-Job Safety Meeting; Caution; Communication; PPE – Personal Gas Monitor, Respiratory Protection
PINCH POINTS	Procedure Training; Pre-Job Safety Meeting; Caution; PPE
EYE INJURY	Procedure Training; Pre-Job Safety Meeting; Caution; PPE – Eye Protection
EXTREME WEATHER (COLD & HEAT)	Pre-Job Safety Meeting; Communication; Weather Watch; Caution; PPE
MUSCULOSKELETAL INJURY	Procedure Training; Pre-Job Safety Meeting; Caution; Frequent Breaks; Stretching

GUIDELINES & INFORMATION

Even small irregularities inside the pipe can cause turbulence in the product flow. Turbulence increases friction loss, reduces capacity, and puts unnecessary load on the pumps and compressors. Greater amounts of debris or deposits in the line increase turbulence and reduce pipe bore and decrease capacity.

Compressed air, high-pressure pumps or existing pipeline gas pressure are some of the methods used for cleaning pipelines with the use of a tank truck or catch tank attached to the discharge end of the pipeline, venting to atmosphere.

PROCEDURE

1. Complete a Pre-Job Safety Meeting to identify all hazards and implement appropriate controls.
2. Ensure Emergency Response Plan is in place
3. Discuss the following job details with the oil company representative:
 - Anticipated amount and type of fluid/debris,
 - Intended method to be used to displace pipeline (compressed air, pipeline gas pressure, high-pressure pumping, etc.)
 - Initial and anticipated pressures, record before and after,
 - Capacity of tank truck or catch tank and means of disposing the recovered fluid (Secure Energy, Aqua Terra, vac truck, etc.) as well as any associated charges for flushing (cleaning) the tank if deemed necessary.
4. Spot tank truck/catch tank down-wind an appropriate distance from pipeline outlet. Turn off engine, lights etc.
5. Open tank hatches, remove cap from degasser vent and attach windsock to pivot.
6. Lay out flowline. Where large amounts of mud are expected, the use of a six (6) meter Kelly hose (adequately pressure rated) rather than the 2” hose reel flowline is recommended to lessen the chance of plugging off the flowline. If using the hose reel flowline, un-spool the entire length, in accordance with Swab Master Hose Reel Procedure.
7. Hook-up ground bonding cables.
8. Install pressure rated fittings and unions on the pipeline discharge ensuring that the valve in place is in good working condition to allow full control of discharging fluid etc.
9. Install a pressure gauge before the valve to allow constant monitoring of the pipeline pressure.
10. Blow hose or flow line clear with gas pressure.



11. Monitor amount of fluid recovered in tank truck/catch tank periodically to prevent over-filling.
12. The oil company representative will decide when the pipeline blow-down is completed.
13. Upon completion of job... disconnect bonding cable and spool up flowline in accordance with Swab Master Hose Reel Procedure.
14. Close tank hatches securely, replace cap on degasser vent and remove windsock.
15. Ensure Fluid Transfer Form is filled out accurately and completely.
16. Ensure labels and placards are in place.
17. Dispose of recovered fluid as instructed by oil company representative or Rig Supervisor.
18. Clean and flush tank of mud, solids, or hydrocarbons if it was deemed necessary by the oil company representative.
19. Return to base by using the same policies and procedures.
20. Park back at shop using hand signals to a safe spot.
21. Do post trip inspections on trucks and equipment.
22. Repair or report damaged equipment for next use.
23. Leave trucks and shop in safe condition.

PLUNGER RETRIEVAL PROCEDURE

APPLICATION

Plunger Retrieval – Removing plunger from well. Refer to **SWABBING PROCEDURE - GENERAL** for more information.

HAZARDS & CONTROLS

PRESSURE	Procedure Training; Pre-Job Safety Meeting; Caution; PPE
FIRE & EXPLOSION	Procedure Training; Pre-Job Safety Meeting; Caution; PPE
CHEMICALS	WHMIS Training; Pre-Job Safety Meeting; MSDS; Caution; PPE
PINCH POINTS	Pre-Job Safety Meeting; Procedure Training; Caution; PPE

PROCEDURE

1. Review the pre-job safety meeting to ensure all hazards are still identified and proper controls are in place. Also ensure the emergency response plan is still applicable.
2. Review the following job details:
 - Plunger information – length, fish neck, type, and size, etc.
 - type of fluid in the tubing and annulus
 - anticipated fluid level
 - initial and anticipated well pressures
3. record starting pressures,
4. attach appropriate retrieval device to tool string,

****NOTE: Flowline should be closed for the remainder of the procedure to maintain well control and prevent unwanted upward movement of the plunger.**
5. Run into hole at a constant speed.
6. Stop above target; note weight indicator and let tool string settle out.
7. Continue to target depth.
8. Pull up a little over string weight to ensure a good latch on the plunger then hit down lightly to latch onto fishneck.
9. Repeat, if necessary, with an oversized skirt on retrieval tool.
10. When latched come out of well
11. Close master valve



POURING SOCKET ROPE PROCEDURE

APPLICATION

For use in connecting tools to the sand line.

HAZARDS & CONTROLS

EYE INJURY	Procedure Training; Pre-Job Safety Meeting; Caution; PPE – Eye Protection
FIRE & EXPLOSION	Procedure Training; Pre-Job Safety Meeting; Caution; PPE
BURNS	Procedure Training; Pre-Job Safety Meeting; Caution; PPE
CHEMICALS	WHMIS Training; Procedure Training; Pre-Job Safety Meeting; MSDS; Caution; PPE

GUIDELINES & INFORMATION

Do not allow water or sweat to hit hot Babbitt – it will splatter easily and cause burns to skin.

Refer to the USE OF PROPANE section for additional information.

PROCEDURE

1. Complete a Pre-Job Safety Meeting to identify all hazards and implement appropriate controls.
2. Ensure Emergency Response Plan is in place
3. Do a slip and cut (Refer to SLIP & CUT SAND LINE PROCEDURE)
4. Prep tiger torch, unravel hose, attach, and make sure it does not have any leaks in the connections.
(Refer to USE OF PROPANE)
5. Assess and remove all flammable hazards before lighting the tiger torch.
6. Light tiger torch
7. Hang rope socket above Babbitt tray
8. Using tiger torch, heat the rope socket until all the Babbitt has been removed, when the rope socket cools remove sand line and inspect the rope socket
9. Slide rope socket down over new line and prep for making rats nest.
10. Twist apart the 3 main strands that form your sand line
11. Taking 1 strand at a time, twist apart the strands so that the 19 wires are somewhat separated. Cut off all small wires.
12. Grip each wire about ¼ inch down and bend them at approx. 180 degrees when each wire has been bent repeat steps until all 3 strands have been bent over.
13. Now as best as you can twist the 3 main strands back into original position
14. Using pliers squish the rat’s nest as tight as you can, then slide the rat’s nest into the rope socket. So that it is below the overflow hole in the rope socket. Tie a strip of rag to the line, tight against the socket.
15. Secure rope socket so that you can pour in the Babbitt.
16. Using tiger torch heat Babbitt tray, until Babbitt turns to liquid; you know it’s hot enough when you can’t feel any hard chunks and Babbitt doesn’t stick to your knife.
17. Scrape away excess dirt and debris from the top of your liquefied Babbitt
18. Heat up the secured rope socket using tiger torch to prevent splattering of Babbitt
19. Assess workspace and remove any tripping hazards in your path before picking up the Babbitt pot
20. Pour Babbitt slowly into the rope socket, while having someone tap rapidly on the side, to help the Babbitt settle.
21. When the Babbitt comes out the overflow hole, stop pouring, keep tapping until Babbitt solidifies.

USE OF PROPANE

APPLICATION

Use of Propane for heating Babbitt. Refer to **USE OF GAS CYLINDER** for handling and storage and refer to **PROPANE SAFETY** section under the **CHEMICAL, BIOLOGICAL AND HARMFUL SUBSTANCES POLICIES**

HAZARDS & CONTROLS

EYE INJURY	Procedure Training; Pre-Job Safety Meeting; Caution; PPE – Eye Protection
FIRE & EXPLOSION	Procedure Training; Pre-Job Safety Meeting; Caution; PPE
BURNS	Procedure Training; Pre-Job Safety Meeting; Caution; PPE
PRESSURE	Procedure Training; Pre-Job Safety Meeting; Caution; PPE

GUIDELINES & INFORMATION

- Propane is used during the task of Pouring Rope Socket.
- Since propane is heavier than air and invisible, it is a special concern when it is used on the jobsite. Please refer to the MSDS information in your MSDS folder on Propane.
- All installations and use of this product on the jobsite must comply with the Government Legislation set out for its safe use.
- Tanks are not heated to increase flow.
- When in use, propane bottles are to be securely held in an upright position.
- Tanks are not to be hooked up and used without proper regulations & all tanks are to be left outside.

USE OF GAS CYLINDER

Compressed gases have the potential for creating hazardous working environments. All worksites including the main shop at Swab Master Ltd. using compressed gas cylinders need to be aware of the safe use, handling, and storage requirements of the compressed gases they work with. As a minimum, this guiding document needs to be reviewed by all staff prior to commencing work with compressed gas cylinders.

Workers: When working with compressed gas cylinders workers must:

- Review this procedure prior to working with compressed gas.
- Review the Safety and Operating instructions for use of “single and two stage regulators)
- Follow the procedures and any additional requirements determined by the supervisor regarding compressed gas cylinder handling, use, and storage
- Report hazardous conditions immediately to their supervisor.
- Wear and properly maintain the required Personal Protective Equipment
- compressed gas containers are used, handled, stored, and transported in accordance with the manufacturer’s specifications,
- compressed gas cylinders, piping, and fittings are protected from damage during handling, filling, transportation, and storage,
- compressed gas cylinders are equipped with a valve protection cap if manufactured with a means of attachment, and
- oxygen cylinders or valves, regulators, or other fittings of the oxygen using apparatus or oxygen distributing system are kept free of oil and grease.

HAZARDS OF WORKING WITH COMPRESSED GAS

Specific Chemical Properties of the Gas – Gases may be combustible, explosive, corrosive, toxic, inert, or a combination of these properties.



Asphyxiation – Gases escaping from a cylinder can expand, rapidly displacing the oxygen in the area to below what is required to support life.

Extreme Cold – Frostbite – Gases escaping from a cylinder may be very cold (e.g., propane) and can cause frostbite. Severe frostbite can lead to serious permanent skin damage.

High Pressure – Damaged cylinders can become projectiles or spin out of control with the rapid uncontrolled release of gas.

Injection - Gas from pinhole leaks in lines can be injected into skin in direct contact with the leak.

Manual Handling – Cylinders are heavy and have been known to cause crush and musculoskeletal injuries.

The gas cylinder storage compartment must be fabricated and assembled in such a way that gases or vapors arising in the compartment cannot flow to, and accumulate in, adjoining compartments.

REGULATORS

See operating instructions on “Single and Two stage regulators” (victor) for safe work procedures. This regulator has specific safety and operating instructions.

The following is a general guideline for using regulators

Never use a compressed gas without a pressure reducing regulator marked for its maximum cylinder pressure, designed for the specific gas that will reduce the pressure to the design of your system.

- Regulators should have a gauge to measure the cylinder pressure and another to monitor the outlet pressure.
- Use only regulators compatible to the valve connector of the gas being used. NEVER USE AN ADAPTOR BETWEEN A CYLINDER AND A PRESSURE-REDUCING REGULATOR.
- Use backflow check valves and engine regulators on each hose whenever both flammable and oxidizing gases are attached to the same system or device and backflow check valves when high pressure and low-pressure gases are connected to the same system.
- Wear safety glasses when connecting or disconnecting regulators.
- Never use grease, lubricating materials or an aid (e.g., pipe dope or Teflon tape) between the threads of the cylinder and pressure reducing regulator.
- Leak test using soap and water or SNOOP™ after making a connection.

HANDLING

Movement within a building:

- Only move a cylinder, even for short distances, with the regulator removed, the cylinder valve closed, and the safety cap screwed in place.
- Do not drop or strike cylinders.
- Do not lift or move cylinders by the cap.
- Transport cylinders in an upright position using a cart designed for that purpose and only with the retaining chain or strap in place.
- Restrict movement of cylinders without a cart within the work area to distances of less than 2 metres.

TRANSPORT

- If a gas cylinder needs to be transported by vehicle and you need clarification, contact the vendor or Supply Chain for assistance.

STORAGE

- Cylinders not **in use** are in storage and must be in a designated area designed for that purpose and that are compliant with the **Alberta Building Code** and the **Alberta Fire Code**.
- Storage areas must be clearly identified. Full cylinders must be stored separate from empty cylinders.
- Quantities of stored compressed gas cylinders must comply with Part 3 of the Alberta Fire Code 2006.
- Separate stored cylinders by compatibility group:
 - ✓ Corrosives from flammables

- ✓ Flammables from oxidizers
- ✓ Oxygen cylinders a minimum of twenty feet from flammable gas cylinders or separated by a non-combustible barrier at least five feet high.
- Empty cylinders must be identified with tape or other method of tagging and labelled “empty” or “MT”.
- Cylinders must be stored so that they are properly secured with a chain or strap to prevent them from falling.
- Multiple cylinders should be stored in a racking system or individually secured.
- Storage of multiple cylinders, outside a racking system, with a single chain should be avoided. If several cylinders must be stored with one retaining chain, then they should be nested to always provide three points of contact with other cylinders and/or the chain.
- Cylinders must be stored in an upright position unless specifically designed to be on their side.
- Store cylinders so that they are used in the order received. Gas in cylinders can degrade over time and, therefore, unless a shorter maximum retention time is suggested by the manufacturer cylinders should be returned to the vendor within 36 months of receipt. Documentation from the supplier stating an expiry date greater than 36 months from date of receipt is also acceptable.

PRESSURE UNIT PROCEDURE

PRESSURE UNIT OPERATION

Purpose

This procedure documents a system and provides general information relating to the set-up and operation and use of Pressure Truck. Specific procedures are required to address individual pipeline systems. It describes the minimum mandatory requirements for tailgate meetings, the wearing of PPE, special items of equipment and/or tools needed, materials necessary, and the job steps to ensure that the work is successful and in compliance with pertinent Codes, Acts and Regulations.

Scope

This section defines the policy regarding operation of the portable boiler on and around sweet and sour pipelines as part of any project work undertaken on behalf of the company and where company or subcontractor personnel and/or equipment are used to complete the work. Customer standard work permit requirements. Safety checks must be carried out prior to commencement of the work. The type of records and any other documentation that must be completed prior to the work commencing, during the work process or after the work is completed.

Requirements

- The project supervisor shall develop in conjunction with the owner’s representative, operations and/or control center, a site-specific procedure which will address such issues as necessary permits, required pressure, water line preparation, and tag-out/lock-out procedure.
- The project supervisor shall arrange/schedule equipment and materials at least (4) four days prior to full date and address volumes of product required.
- The project supervisor shall ensure that all personnel on the site have relevant satisfactory qualifications and training i.e., Client orientation, WHMIS 2015, PCST or CSO, First Aid and H2S.
- Project supervisor will conduct a safety meeting with all personnel and subcontractors involved:
 - Filling procedure will be reviewed.
 - Maximum pressures.
 - Emergency procedures developed.
 - Necessary signage and flagging determined.

General

The pigging of oil and gas pipelines is a common procedure involving introducing a pig or ball of some type to the inlet of a pipeline (launcher) and forcing the pig to the outlet (receiver). The pig is used to clear the line and/or remove all water that was used to pressure test the line. During these operations great care must be taken to ensure the isolating valves are holding. Proper procedures must be followed.

Winterizing Unit

- Drain all water from the tank.
- Pump out water from the hose.
- Fill the compartment with winter fluid.
- Open sump valve #106 or #110.
- Open tank top hatch.
- Place the hose in top of tank hatch opening.
- Open valve #101 or #105 on the front or rear compartment.
- Close valves #106 or #110.
- Turn hose reel 2-way valve to open position.
- Pump fluid using low pressure pump through piping and hose.
- Run pump in a forward position.

Blow Down Pressure Back to Tank

- Open tank hatches.
- Open front or back tank sump valves #106 or #110.
- Turn hose reel 2-way valve to **vertical position** to open.
- Control blow-down rate at the test head at the predetermined pressure/rate.

Open position

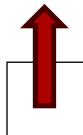

Caution: 2-way valve seats can become washed out if this is used on a regular basis.

Loading and Unloading Fluid into Tank

- Open tank hatches.
- Connect 2" suction hose.
- Open valve #109 D.S Header Discharge or valve # 104 P.S Header Discharge.
- Open front or rear valve # 106 or #110 sump valve to unload.
- Open valve #107 and/or #102 to load.
- Run low pressure pump in the pulled back position.

Returning Fluid to Tank Tops

- Open hatches.
- Use a 1" high pressure hose.
- Confirm all valves are closed.
- Open valve #101 and/or #105.
- Open tank top valves #101 and/or #105 front rear compartment
- Load fluid using valve #101 and/or # 105.
- Turn hose reel 2-way valve handle to the **horizontal position**.
- Run low pressure pump in forward position.

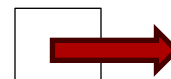

Pressuring Up Lines

- Open top hatches.
- Open front or rear compartment sump valve #106 or #110.
- Open high pressure supercharge suction #103.
- Open 1" valve on tri-plex pump.
- Turn hose reel 2-way valve to **horizontal** position. **Closed position**
- Close hose reel needle valve.
- Pre-set pressure relief valve to predetermined pressure.
- Set low pressure pump lever forward to feed high pressure pump.
- Set high pressure pump desired rate. **Note: maximum rate of 53 LPM**
- Bleed pressure off high pressure line.
- Open needle valve on/by hose reel.

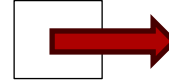

Pressure Truck

- Open top load valve.
- Use 3-way valve to suck back.
- Tank gauges are not accurate.
- Feed from truck or fill through overflow lines with hatches open.
- Computer shut down button, left hand on screen – tap twice.

Sump & Vent Hooked Together

- #1 front comp load
- #6 front comp
- #3 super charge suction
- Regulator in for more pressure and out for less pressure.
- To set regulator – bleed off pressure then set at 2000psi.

PRESSURE UNIT SPECS

Pressure Unit Specs:

- Mounted on a newer model dually chassis crew cab
- Once rigged onto equipment needing pressure testing, the operation can be completely controlled from inside the cab utilizing control panel
- Separate air compressor mounted for operation of air actuated valves
- All piping, hoses, fittings, tank (VKIP) and truck (CVIP) have up-to-date certifications (tested yearly)
- High pressure piping and hoses capable of pressures up to 5000 psi
- Low pressure hoses (2") tested to 150 psi
- 3178 litre capacity tank (2 compartments @ 1589 litre each, that can be utilized in conjunction with, or separately, for different fluids/chemicals)
- High pressure tri-plex pump capable of 53 l/min max and as low as 1 l/min (CAT Pump Model 3560)
- Discharge 1" up to 5000psi
- Max Load Rate: 2000L/m @ 20.9 kpa
- Max Unload Rate: 1500 L/m @ -3 kpa
- Tank spec TC406
- Digital flow meter/counter



Pressure Unit Applications:

- Pressure testing that includes but are not limited to: Well heads and piping
- Pumping chemicals
- Holding backside pressure for fracturing

Fluids that can be hauled:

- Condensate (sweet & sour)
- Corrosion Inhibitor
- Inlet Condensate
- Methanol
- Paraffin Solvent & Dispersant
- Produced Water (Sweet & Sour)
- Scaler Inhibitor
- Triethylene Glycol 90/10
- Fresh Water

SAMPLE BAILER PROCEDURE

APPLICATION

The Sample Bailer is used to retrieve a sample of downhole material such as scale or sand that may be causing an obstruction within the wellbore.

HAZARDS & CONTROLS

PRESSURE	Procedure Training; Pre-Job Safety Meeting; Caution; PPE
PINCH POINTS	Procedure Training; Pre-Job Safety Meeting; Caution; PPE
H2S	H2S Training; Procedure Training; Pre-Job Safety Meeting; Communication; Caution; PPE – Personal Gas Monitor, Respiratory Protection
FIRE & EXPLOSION	Procedure Training; Pre-Job Safety Meeting; Caution; PPE
CHEMICALS	WHMIS Training; Procedure Training; Pre-Job Safety Meeting; MSDS; Caution; PPE
EXTREME WEATHER (COLD & HEAT)	Pre-Job Safety Meeting; Communication; Weather Watch; Caution; PPE
MUSCULOSKELETAL INJURY	Procedure Training; Pre-Job Safety Meeting; Caution; Frequent Breaks; Stretching

GUIDELINES & INFORMATION

1. Available in two basic designs with ball or flapper shoe
2. Components:
 - Fishneck
 - Barrel
 - Ball or Flapper
 - Shoe
3. Attach adequate weight bars below the spang jars to provide enough weight to force the bailer into the debris, thus forcing the material upward past the ball or flapper into the barrel. The ball has limited travel due to the cross pin through the barrel and typically should relax onto the ball seat after the barrel is filled, thus trapping the sample inside the barrel.

See a Sample Bailer diagram on the next page...

Sample Bailer



1. toolstring equipment

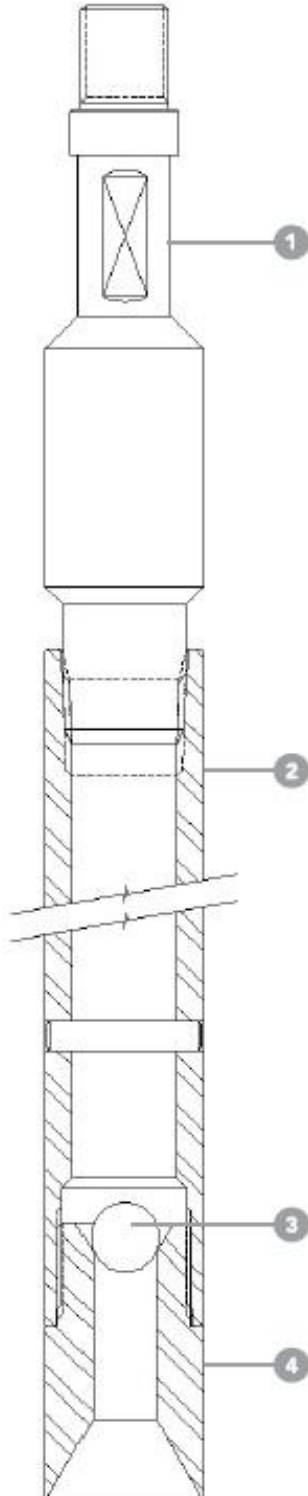

PURPOSE

To obtain sample material from the bottom of the wellbore, or other obstructions caused by sediment, or scaling in wellbore.

ASSEMBLY PARTS

- 1. Fishneck
- 2. Barrel
- 3. Ball
- 4. Shoe

DESCRIPTION

The Sample Bailer is operated by jarring down into the debris in wellbore and thus forcing the material upward past the ball into the barrel. The ball has limited travel due to the cross pin through the barrel and typically should relax onto the ball seat after the barrel is filled, thus trapping the sample inside the barrel.

NOTE

The Sample Bailer may be ran in unison with the Tubing End Locator by substituting the solid fishneck for the Tubing End Locator.

Nominal Size		2.0"
Assembly Number		0601TLS200A0
Item	Part Name	
1	Fishneck	0601CO17101
2	Barrel	0601TLS20001
3	Ball	0.75" Chrome Steel
4	Shoe	0601TLS20002
Upper Thread Connection		0.938"-10 UN 2A
Max O.D.		1.71"
Fishneck size		1.375"



SAND PUMP BAILER PROCEDURE

APPLICATION

The Pump Bailer is used to remove loose sand, silt or mud plugs encountered as a bridge or in the lower cellar portion of the well. It may also be necessary to remove such debris above wire line tools/equipment to allow retrieval. The Pump Bailer is a hollow tube with a check valve (flapper or ball type) at its lower end. It contains a piston and valve attached to a rod which passes through a loose hold (for fluid bypass) at the upper end of the tube. The rod is attached to the tool string. As the bottom of the bailer sits on the sand, the weight of the tool string pushes the piston to the bottom of the tube. As the piston is picked up, it sucks sand and debris into the bottom of the bailer, with the check valve preventing it from falling back out. This slow “stroking process” continues until the bailer is full.

HAZARDS & CONTROLS

PRESSURE	Procedure Training; Pre-Job Safety Meeting; Caution; PPE
PINCH POINTS	Procedure Training; Pre-Job Safety Meeting; Caution; PPE
H2S	H2S Training; Procedure Training; Pre-Job Safety Meeting; Communication; Caution; PPE – Personal Gas Monitor, Respiratory Protection
FIRE & EXPLOSION	Procedure Training; Pre-Job Safety Meeting; Caution; PPE
CHEMICALS	WHMIS Training; Procedure Training; Pre-Job Safety Meeting; MSDS; Caution; PPE
EXTREME WEATHER (COLD & HEAT)	Pre-Job Safety Meeting; Communication; Weather Watch; Caution; PPE
MUSCULOSKELETAL INJURY	Procedure Training; Pre-Job Safety Meeting; Caution; Frequent Breaks; Stretching

GUIDELINES & INFORMATION

CAUTION: Bailers can be dangerous after pulling them to the surface and when unloading the sand, due to the possibility of pressure trapped inside the chamber. Caution should therefore be taken when removing the check valve on the bottom to make sure there is no pressure inside. This can usually be determined by how hard it is to unscrew. You should never completely remove the bottom while the bailer is pressured up. Do not hammer on a bailer to remove sand. These bailers are subject to bottom-hole pressure; therefore, they need to be visually inspected for wear and wall reduction.

PROCEDURES

1. Complete a Pre-Job Safety Meeting to identify all hazards and implement appropriate controls.
2. Ensure Emergency Response Plan is in place
3. Review the following job details:
 - type of fluid in the casing or tubing and annulus
 - anticipated fluid level
 - pressures recorded with a gauge or electronic deadweight
 - Check available well and down hole data to ensure that the proper tool type and size are run
4. Record initial tubing and casing pressures
5. Attach bailer to the tool string
6. Before running the tool string into the well, make a sketch of the total tool string, noting the length, as well as the internal and external diameters.
7. Bleed off pressure as necessary and lower tool string into the well at a constant rate
8. Sand bridges in the tubing, if encountered, will require more precautions due to the possibility of pressure trapped beneath. When the bailer falls through a bridge, the tools should be pulled back up a few meters above where the bridge was first encountered to make sure the bridge of sand is completely clear before going deeper. Continue lowering tool string until reaching the section of bulk sand.

9. Techniques may vary, but after a few trips, the operator should know what is required to get the bailer full each trip.
10. Continue bailing until the bulk of sand has been removed and/or until the bailer is resting on the plug or whatever is to be removed.

Sand Pump Bailer

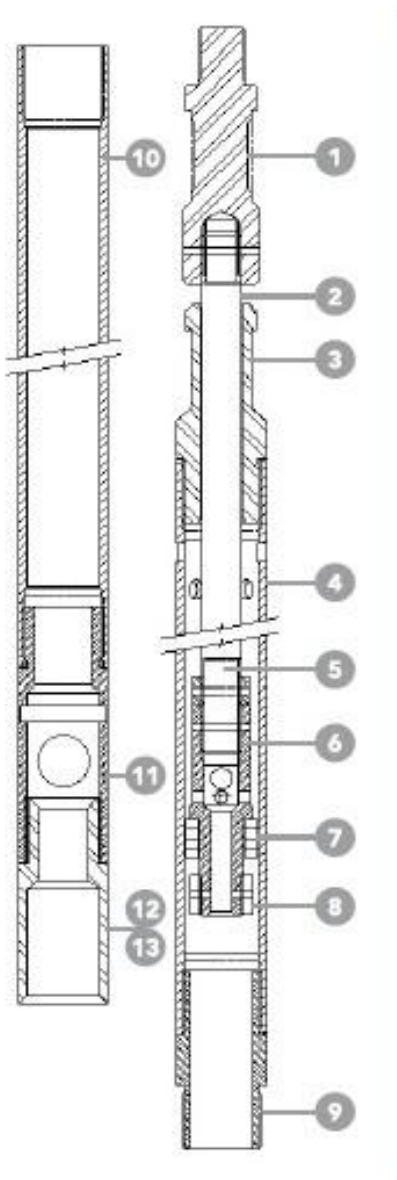

PURPOSE

Sand pump bailer/ Stroke Bailer is a type of bailer that incorporates piston within a cylinder that while stroked upwards, draws sand or debris into the cylinder chamber. These tools are used for the recovery of loose debris and sand from within the wellbore.

ASSEMBLY PARTS

1. Fishneck
2. Stroke Rod
3. Piston Stop
4. Pump Barrel
5. Rod Nut
6. Piston
7. Wobble Washers
8. Piston Nut
9. Tandem Sub
10. Load Barrel
11. Ball Housing
12. Blind Shoe
13. Mule Shoe

OPERATION

Assemble the Sand Pump with the desired shoe (ball / flapper) and hoist into lubricator. Lower into wellbore to top of debris. Gently set down on top of debris until the stroke section of the bailer is closed, attempt to retrieve debris by opening and closing the stroke bailer, thus creating a vacuum and filling the load barrel with debris. Once the load barrel has been filled, remove equipment from wellbore and empty any debris from the load barrel.

PRECAUTIONS

The Sand Pump should be periodically pulled from debris so as not to get stuck or trapped in material that is being bailed. Always ensure that when emptying the sand pump that all threads are clean and free from debris as to prevent damage to the threads when assembling.

SIZES ON THE NEXT PAGE...

ELEMENT #3: HAZARD CONTROL



Nominal Size		0.875"	1.00"	1.25"	1.37"	1.50"
Assembly Number		0601SB087A0	0601SB100A0	0601SB125A0	0601SB138A0	0601SB150A0
Item	Part Name					
1	Fishneck	0601SB08701	0601SB10001	0601SB12501	0601SB12501	0601SB15001
2	Stroke Rod	0601SB08702	0601SB08702	0601SB12502	0601SB12502	0601SB15002
3	Piston Stop	0601SB08703	0601SB10003	0601SB12503	0601SB13703	0601SB15003
4	Pump Barrel	0601SB08704	0601SB10004	0601SB12504	0601SB13704	0601SB15004
5	Rod Nut	0601SB08705	0601SB08705	0601SB12505	0601SB12505	0601SB15005
6	Piston	0601SB08706	0601SB10006	0601SB12506	0601SB13806	0601SB15006
7	Wobble Washers	N/A	N/A	0601SB12507	0601SB13807	0601SB15007
8	Piston Nut	N/A	N/A	0601SB12508	0601SB13808	0601SB15008
9	Tandem Sub	0601SB08709	0601SB10009	0601SB12509	0601SB13809	0601SB15009
10	Load Barrel	0601SB08710	0601SB10010	0601SB12510	0601SB13710	0601SB15010
11	Ball Housing	0601SB08711	0601SB10011	0601SB12511	0601SB13711	0601SB15011
12	Blind Shoe	0601SB08712	0601SB10012	0601SB12512	0601SB13712	0601SB15012
13	Mule Shoe	0601SB08713	0601SB10013	0601SB12513	0601SB13713	0601SB15013
14	Flapper Saver Sub	N/A	N/A	N/A	N/A	0601SBF15001
15	Flapper	601SBF08702	0601SBF10002	0601SBF12502	0601SBF13702	0601SBF15002
16	Flapper Shoe	0601SBF08703	0601SBF10003	0601SBF12503	0601SBF13703	0601SBF15002
17	Removable Flapper	N/A	N/A	N/A	N/A	N/A
18	Removable Ring	N/A	N/A	N/A	N/A	N/A
19	Check Ball	0.437"	0.437"	0.62"	0.75"	0.937"
Top Thread Connection		0.50"-13 UNC	0.625"-11 U NC	0.938" - 10 UN	0.938"-10 UN	0.938"-10 UN
Fishneck size		0.75"	0.75"	1.187"	1.187"	1.187"

Nominal Size		1.62"	1.75"	2.125"	3.25"	3.50"
Assembly Number		0601SB162A0	0601SB175A0	0601SB212A0	0601SB325A0	0601SB350A0
Item	Part Name					
1	Fishneck	0601SB16201	0601SB16201	0601SB17501	0601SB32501	0601SB32501
2	Stroke Rod	0601SB16202	0601SB16202	0601SB16202	0601SB32502	0601SB35002
3	Piston Stop	0601SB16203	0601SB17503	0601SB21203	0601SB32503	0601SB35003
4	Pump Barrel	0601SB16204	0601SB17504	0601SB21204	0601SB32504	0601SB35004
5	Rod Nut	0601SB15005	0601SB16205	0601SB16205	0601SB32505	0601SB32505
6	Piston	0601SB15006	0601SB16206	0601SB20006	0601SB32506	0601SB35006
7	Wobble Washers	0601SB16207	0601SB17507	0601SB21207	0601SB32507	0601SB35007
8	Piston Nut	0601SB15008	0601SB16208	0601SB20008	0601SB32508	0601SB32508
9	Tandem Sub	0601SB16209	0601SB17509	0601SB21209	0601SB32509	0601SB35009
10	Load Barrel	0601SB16210	0601SB17510	0601SB21210	0601SB32510	0601SB35010
11	Ball Housing	0601SB16211	0601SB17511	0601SB21211	0601SB32511	0601SB35011
12	Flat Shoe	0601SB16212	0601SB17512	0601SB21212	0601SB32512	0601SB35012
13	Mule Shoe	0601SB16213	0601SB17513	0601SB21213	0601SB32513	0601SB35013
14	Flapper Saver Sub	0601SBF16201	0601SBF17501	0601SBF21201	0601SB32514	0601SB35014
15	Flapper Bottom	0601SBF16202	-	-	-	-
16	Flapper	0601SBF16202	0601SBF17502	0609SBF16202	0601SBF32501	0601SBF35001
17	Removable Flapper	N/A	0601SBF175A0	0609SBF212A0	0601SBF32503	0601SBF35002
18	Removable Ring	N/A	0601SBF17503	0601SBF21203	0601SBF32507	0609SBF32502
19	Check Ball	0.937"	1.00"	1.437"	2.00"	2.00"
Top Thread Connection		0.938"-10 UN	0.938"-10 UN	0.938"-10 UN	1.062"-10 UN	1.062"-10 UN
Fishneck size		1.187"	1.375"	1.375"	2.31"	2.31"

SAND LINE INSPECTION PROCEDURE

APPLICATION

Sand line inspection is required to monitor the working condition of the sand line. To ensure sand line is in proper working condition you must check that there are no frays, cracks, flat spots, or kinks. Sand line needs to be monitored weekly by visually inspecting and constantly measuring with a vernier caliper.

HAZARDS & CONTROLS

PRESSURE	Procedure Training; Pre-Job Safety Meeting; Caution; PPE
PINCH POINTS	Procedure Training; Pre-Job Safety Meeting; Caution; PPE
H2S	H2S Training; Procedure Training; Pre-Job Safety Meeting; Caution; PPE – Personal Gas Monitor, Respiratory Protection
FIRE & EXPLOSION	Procedure Training; Pre-Job Safety Meeting; Caution; PPE
CHEMICALS	WHMIS Training; Procedure Training; MSDS; Pre-Job Safety Meeting; Caution; PPE
EYE INJURY	Procedure Training; Pre-Job Safety Meeting; Caution; PPE – Eye Protection
SLIP / TRIP / FALL	Pre-Job Safety Meeting; Caution; PPE – Anti Slip Steel Toes, Ice Grips
EXTREME WEATHER (COLD & HEAT)	Pre-Job Safety Meeting; Communication; Weather Watch; Caution; PPE
MUSCULOSKELETAL INJURY	Pre-Job Safety Meeting; Procedure Training; Caution; Frequent Breaks, Stretching

GUIDELINES & INFORMATION

- Be aware at all times of your body position in relation to the wire.
- It is important to measure the diameter of the sand line over the entire available working length and document it to provide an ongoing record of overall line wear. It is not uncommon to have a variation

of up to 0.050” diameter on the line due to normal wear caused from the line dragging along the surface of the casing tubing while swabbing as well as wear caused from stripping through the saver head.

- For example, during a routine line calibration the sand line measured 0.490” at a section closer to the core and decreased in size gradually and continuously when calipered every 200m – to the rope socket where the diameter measured 0.440
- Non-scheduled inspection is required when installing flags as well as any time that an excessive pull took place.

PROCEDURE

1. Complete a Pre-Job Safety Meeting to identify all hazards and implement appropriate controls.
2. Ensure Emergency Response Plan is in place
3. Rig in as usual, (refer to **SWABBING PROCEDURE - GENERAL** so that you are ready to run into the well.
4. Have one employee operating the break handle and pack off pump and the other employee next to the sand line drum. Make sure the employee stands clear of the line and drum whenever it is running. Give the stand clear signal to the employee and make sure you receive acknowledgement before running the line.
5. Wipe any dirt and mud from the sand line surface so that you can visually inspect line for wear, cracks, flat spots, kinks, and frays. Mark all defects with chalk.
6. Measure and record diameter of wire.
7. Unpack, let some line into the well, 100 - 200m, pack off again now you have another section to inspect and measure.
8. Repeat steps 3-4 until all working line has been inspected, measured, and recorded. If less than 0.045”, slip and cut line. (Refer to **SLIP & CUT SAND LINE PROCEDURE**)
Note: The minimum acceptable diameter for working line is 10% undersized from original. (Refer to wrap sheet of your line).
9. In the event of “hard fluid tags” or “cat’s ass” pack off and allow slack in the line. This will show if you have any kinks in the line.



- If you are not completely sure whether the line has defects or not, report to management and ask them to inspect it for you.

SLIP & CUT SAND LINE PROCEDURE

APPLICATION

To remove damaged and / or undersized Sand line.

HAZARDS & CONTROLS

PINCH POINTS	Procedure Training; Pre-Job Safety Meeting; Caution; PPE
EYE INJURY	Procedure Training; Pre-Job Safety Meeting; Caution; PPE – Eye Protection
SLIP / TRIP / FALL	Pre-Job Safety Meeting; Caution; PPE – Anti Slip Steel Toes, Ice Grips
EXTREME WEATHER (COLD & HEAT)	Pre-Job Safety Meeting; Communication; Weather Watch; Caution; PPE

PROCEDURE

- Complete a Pre-Job Safety Meeting to identify all hazards and implement appropriate controls.
- Ensure Emergency Response Plan is in place
- Do a line check on one of your swab wells. Record in meters where you want to chop line, chalk it.
- Find a suitable location “gravel preferably” to slip the line, so nothing catches fire when you pour the rope socket.
- Stand the rig, run out the tool, have a roughneck guide it to the ground.
- Undo rope socket, swivel combo from tools
- Using ½ inch line cutter chop the sand line about 12-18 inches above the rope socket (wear eye protection).
- Pull out an extra 20 metres of sand line and inspect it to be sure it is in good condition. Use calipers to gauge the line
- Pick the spot you want to chop, and then do so. Take off enough to remove flags.
- Inspect the end of the sand line, make sure it’s a clean cut and all wires are shiny not rusty.
- Tape or secure line so that it does not unravel.
- Record in meters how much line you chopped on slip and cut sheet

SIDE ENTRY PROCEDURE - TOOL RETRIEVAL / COIL CLEAN OUT

APPLICATION Tool Retrieval - Stuck in Well Procedure

HAZARDS & CONTROLS

FIRE & EXPLOSION	Procedure Training; Pre-Job Safety Meeting; Caution; PPE
PINCH POINTS	Pre-Job Safety Meeting; Caution; PPE
PRESSURE	Procedure Training; Pre-Job Safety Meeting; Caution; PPE
MUSCULOSKELETAL INJURY	Procedure Training; Pre-Job Safety Meeting; Caution; Frequent Breaks; Stretching
H2S	H2S Training; Procedure Training; Pre-Job Safety Meeting; Communication; Caution; PPE – Personal Gas Monitor, Respiratory Protection
EYE INJURY	Pre-Job Safety Meeting; Caution; PPE – Eye Protection
CHEMICALS	WHMIS TRAINING; Procedure Training; Pre-Job Safety Meeting; Caution; MSDS; PPE
EXTREME WEATHER (COLD & HEAT)	Pre-Job Safety Meeting; Communication; Weather Watch; Caution; PPE
SLIP / TRIP / FALL	Pre-Job Safety Meeting; Caution; PPE – Anti-Slip Steel Toes; Ice Grips



PROCEDURE

1. Complete a Pre-Job Safety Meeting to identify all hazards and implement appropriate controls.
2. Ensure Emergency Response Plan is in place
3. Review the following job details:
 - type of fluid in the tubing and annulus
 - anticipated fluid level
 - initial and anticipated well pressures
 - depths
4. Check well data information to help determine obstructions, examples are
 - frac or formation sand if you are stuck below perforations
 - stuck in sliding sleeve
 - nipple
 - casing patch etc.
5. Use your jars to hammer up to free your tool. (Mark sand line with chalk to keep track of your movement. Counter can get out a few meters when going up and down.)
6. If you are still not free put about a meter of slack in your line with the chalk to see if the tool will fall and free itself.
7. When well is slack, pack off saver head and close flow line letting well build pressure, it could take 20 to 30 minutes. Have your assistant open the flow line; while watching your line if the tool drops and the line tightens try to pull out of the well.
8. If unsuccessful close flow line, pack off again, pull into line 2000 to 3000 pounds and let well pressure build to its normal shut-in pressure. Have your assistant open the flow line, watching your weight indicator. If the weight drops even 100 pounds, try to come out of the well.
9. If this doesn't work, try a larger pull in 6000 – 7000-pound range.
10. If this does not work, call your field contact, and ask if it is okay to put some soap (**refer to drilling detergent MSDS**) down the well. If it is okay, slack line again, bleed down well pressure. If it bleeds right off, pour liquid soap down the well via CT (coil tubing) entry opening. Close CT entry and flow line, pack off, let soap fall to bottom of well, making contact with obstructions.
11. After giving the detergent some time to make contact with obstruction, have your assistant open flow line again. Try working your jars to hammer up and down to release tool. If you are unsuccessful, contact a field representative and/or management.
12. Have conversation about getting a coil tubing company to come in and free tool. Indicate to customer that it is our policy NOT to use our tank truck when conducting a coil tubing air clean out, and the coil unit ordered should have a picker to support the coil injector head and an open top tank to flow to, this helps prevent pressure build up in the tank.

COIL CLEAN OUT – SIDE ENTRY

1. When coil arrives on location hold a safety meeting to go over hazards and discuss procedures.
2. Ask to see the coil tubing companies "Stuck in well" procedure entering the well via CT entry on a swab rig.
3. Go over rigging procedures (make available CT entry certification and engineering limits).
4. Exchange information – Re: well data, depth of tool stuck, type of tool stuck, signs of hydrocarbons, etc.
5. How and when to coordinate efforts at freeing stuck tool, tool string.
6. Swab Master Staff to stay out of harm's way while well CT clean out is taking place.
7. After freeing up the tool and coming to surface inside the lubricator, secure well.
8. Inspect line and tool string to make sure no damage occurred during CT clean out procedure.



Side Entry Lubricator FEA Report for Swab Master Ltd.

The FEA specifications are as follows:

Side Entry Tube: 5-1/2" dia vertical x 4" side entry

Design Pressure: 1333 (psig)

An FEA has been performed on a 3D model of the side entry tube consisting of 5.5" J55 Casing and 4"XX heavy pipe side entry and one 2" 3000# thread-o-let off the side. There are 5.5" 8RD bell nipples at both ends of main pipe. The analysis simulated hydrostatic pressure test performed to 2000 psig. Design pressure of fitting is 1333 psig at design temperature of 100 °F. The Lubricator is manufactured by TCB Welding Brooks, AB.

The minimum wall thickness is 0.20". The side entry piping is to be monitored for around the circumference, the minimum thickness will be reached and piping is to be removed from service and destroyed.

Pharaoh Engineering Ltd.
Permit to Practice # 06287



Robert D. Stolz, P. Eng.
#3, 3295 Dunmore Road S.E.
Medicine Hat, Alberta T1B 3R2
Phone (403) 526-6761
Fax (403) 504-1622
Job No. 236-2008PEL



Swab Master Ltd.	
Revision No. 1 Date : June 1, 2009	Designed by: Rob Stolz, Darko Pecelj Reviewed by: Garth Smith
Area / Location: All Areas	Operation Level : Swabbing Personnel

Critical Task Procedure:	Work Procedure - Coil Tubing Side Entry Clean-out
Work Procedure # -	

Rev	Description	Date	Prepared By	Reviewed By	Approved By Initial
0	Setup Procedure	06/01/09	Rob Stolz	R.S., G.S.	

Purpose:

In certain circumstances swabbing tools become stuck down hole. In these cases a coil tubing rig is called upon to assist in the retrieval of the swab tool. This process is called a side entry cleanout. A "Y" piping section is manufactured to allow the Coil Tubing rig to enter along side the swabbing tool string. This procedure has been developed to assist all personnel working at the well site in such a case. The personnel are to become familiar with hazards and concerns pertaining to doing a side entry clean-out with coil tubing unit. It is the goal of this procedure to protect the health and safety of the all personnel involved in the task. There are a set of guidelines listed below that are to be followed in order to prevent equipment failure, environmental damage, damage to client's property and the public.

Hazards and considerations to Side Entry Clean-out:

The Swabbing rig operator is the point contact for the operation. The physical layout of the work area is to be surveyed to determine if workers can perform the work intended. This would include an ergonomics review of the workers on the job site, and develop a rescue/emergency plan in the event of an accident. Before the side entry is performed the following steps need to take place:

1. Complete form, "Fire and Explosion Hazard Management Plan"; to be completed by all personnel on site. This is to identify any hazard and make all workers aware of these hazards associated with the job. All personal must sign off on the form.
2. Complete form, "Worksite Record of Safety Meeting & Hazard Assessment". This would be a Toolbox meeting with all personnel. The job steps are to be listed along with the hazards and if possible a reduction of the risks. All personnel to sign off.
3. All personnel must be made aware of the equipment to be used in the job.



All personnel are to be made aware of the equipments safe working ratings/limits. This can be for pressure, load, safe working distances from equipment etc. These ratings must not be exceeded.

Side Entry Piping:

The main part being used in this process is the piping fabricated to allow the coil tube unit to enter along side the swabbing rigs string. The piece consists of a 5 ½" J55 casing vertical section with a 4" XXH A106 Gr B pipe coming off the side at "Y" angle. The piping utilizes a K55 bell nipple on both 5 ½" threaded ends. This helps with wall reduction thickness due to the erosion taking place inside the pipe. The piping is to be fabricated by a company certified to fabricate pressure piping systems. They will require a weld procedure and "B" pressure welders. Drawings of the piping are to be kept on file by the swabbing company.

A Finite Element Analysis (FEA) was performed on a 3D model of the piping. The analysis consisted of a simulating a hydrostatic pressure test of 2000 psig, design pressure of 1333 psig, a force simulating a push/pull test of 5 kips on the side entry piping. The push/pull analysis was performed to ensure the weld used to attach the side piping to the vertical pipe does not fail and ensure the 4" pipe does not collapse.

It has been determined from past experience that the side entry piping will corrode/erode. The wall thickness, at or near the threads and at the side entry, needs to be monitored bi-annually or after being stuck down hole. The corrosion rate is to be determined with records kept with the Swabbing rig company. An ultrasonic thickness (UT) gauge is to be used to determine the material thickness. Measurements are to be taken by a qualified individual. The individual is to be trained to use this piece of equipment. The minimum allowable wall thickness on the 5 ½" diameter section of main pipe is to be 0.20". The side entry piping is to be taken out of service and destroyed if the measurements are equal to or less than 0.20".

It is considered once the 5 ½" vertical pipe has reached a thickness less than 0.20", around the side entry perimeter, that minimum thickness is reached and piping is to be removed from service and destroyed.

Coil Tubing Unit Considerations:

When coil tubing units are required for this procedure they must be able to support their own weight; a picker unit is required to support the coil tube. Coil units are to run in the well bore open ended to eliminate the chances of becoming stuck beside the swab tool. This will also generate air flow straight down on the swab cups and tool. This method will have a better chance of cleaning sand off the cups. Coil unit personnel are to do a, "Clean Mule Shoe", to eliminate any sharp edges. The coil tubing unit is to use 1 ¼" O.D. tubing. Coil units must ensure load indicators are accurate to within +/- 1%. All gauges are to be in good working condition.

Certification and Training

- WHMIS Certification
- T.D.G. Certification
- First Aid and CPR
- H2S Alive Training
- Class 3 with Air
- BOP Certification for Coil Tubing Operator
- Fire & Explosion Hazard Management training
- Petroleum Safety Training/IRP-16
- HRS of service training
- Gas Monitor Training

Pre-Job Planning Activities.

- Upon arrival of coil unit identify all hazards and communicate verbally and document all hazards to all personnel on site. All personnel must sign off on all safety meetings/work permits. Every person on site must be made aware of the danger areas of each piece of equipment and understand the dangers present. The discharge side of coil unit and drawworks of swab unit are just a few examples. Discuss with all personnel, the depth at which the tool is stuck and any other relevant information. All personnel on site are to be informed of the equipment ratings of both units. These rating must be followed and never exceeded.
- Fire and Explosion Hazard Management plan must be completed and signed off.
- Remove tech fence apart before backing up coil unit.
- Back up coil tubing unit, supervised at all times.
- Rig in fittings needed to attach coil unit to side entry port.
- Rig injector onto side entry port, ensure injector is supported only by coil unit; use picker truck. The swabbing rig and coil tubing unit operators are to verify alignment. Once alignment is verified the union can be hammered tight. Misalignment will result in unnecessary stress being applied to the side entry pipe.
- Swab unit is to pull line weight on swab tool to ensure there is no slack on the line in well bore.
- Slowly open ball valve to ensure union is tight and has a good seal.
- Make sure valve on lubricator is open and flowing to tank before coil tubing begins running in.
- Run coil tubing into well bore to swab stuck depth and do cleanout on top of swab tool and cups. This may take several hours to free swab tool.
- After good returns are recorded in tank, coil tubing should come up the hole approximately 25 m, then swab unit can pull to see if tool is free. If tool is not free continue on with same process as above.
- If tool is free, coil should start coming up hole, with swab unit following at a minimum distance between the two units of 50 m.
- Once coil tube is at surface, the ball valve must be closed before the swab unit is to pull up into the lubricator.
- Demco/Master valve must be closed before either unit rigs off. Coil tubing unit must be rigged off of lubricator/side entry port first, then swab unit can rig off.
- If the swab tool cannot be unstuck, then it will have to be sheared off. This is only to be done as a **last resort**.



Work Permits Required

- Safe work permit, safety meeting & hazard assessment.
- Fire and explosion hazard management plan.

Both permits are to be completed and signed by all personnel on the job site.

Safety Considerations

- Qualifications of people involved in each aspect of the task
- Safety Watch requirements
- Responsibility of all individuals
- Emergency Plan
- Rescue Procedure
- Communication
- Instrumentation in good working condition
- PPE

Equipment

- All equipment must be properly certified. Instrumentation is to be in good working condition.
- All inspections must be completed and documented with copies available upon request.



SWABBING PROCEDURE - GENERAL

APPLICATION

Swabbing removes production fluid or hydrostatic pressure of a wellbore caused by fluid level and weight of hydrocarbons or production fluid in a string of tubing or casing in a completed well. The purpose of swabbing is to reduce wellbore pressure by physically pulling fluid out of the production string. When wellbore pressure is reduced, this could create a “kick” from the reservoir as the wellbore load is removed. This should initiate flow from the formation. A swabbing tool-string utilizes a sand line and specially shaped swab cups which expand to seal against the tubing wall or casing and carry the liquids from the wellbore to the surface.

HAZARDS & CONTROLS

PRESSURE	Procedure Training; Pre-Job Safety Meeting; Caution; PPE
FIRE & EXPLOSION	Procedure Training; Detection & Control of Fire & Explosion Hazards Training; Pre-Job Safety Meeting; Caution; PPE
H2S	H2S Training; Procedure Training; Pre-Job Safety Meeting; Caution; PPE – Personal Gas Monitor; Respiratory Protection
PINCH POINTS	Procedure Training; Pre-Job Safety Meeting; Caution; PPE
EYE INJURY	Procedure Training; Pre-Job Safety Meeting; Caution; PPE – Eye Protection
EXTREME WEATHER	Pre-Job Safety Meeting; Communication; Weather Watch; Caution; PPE
SLIP / TRIP / FALL	Pre-Job Safety Meeting; Caution; PPE – Anti-Slip Steel Toes; Ice Grips
MUSCULOSKELETAL INJURY	Procedure Training; Pre-Job Safety Meeting; Frequent Breaks; Stretching

PROCEDURE

1. Complete a Pre-Job Safety Meeting to identify all hazards and implement appropriate controls.
2. Ensure Emergency Response Plan is in place
3. Review, discuss and make sure all attendees understand the following job details and well data:
 - Well depth
 - type of fluid in the tubing and annulus
 - anticipated fluid level and initial and anticipated well pressures
 - sweet gas or H2S
 - packers, plugs, bottom hole springs, collar stops, sliding sleeves
 - other in hole equipment
 - sand or wax problems in the past
 - type of swab tools and swab cups to be used ensuring the lubricator is the correct length and size to accommodate the tool string being used.
 - Maximum amount of fluid to be swabbed each pull per hour and
 - Maximum swab depth
4. Ensure that all surface equipment, the lubricator, and BOP's are pressure rated for the work that is being done
5. Make a sketch of the entire tool string noting the length and diameter of each piece. Include internal (ID) and outer (OD) diameters and the date of the drawing. This can be hand drawn but measurements **MUST** be accurate. Keep in the rig in case any tools are lost or become stuck in the well.
6. Walk around well-head and area (may have to move equipment to ensure that there is room for the swab rig and equipment).



7. Move rig to well-head. **NEVER** back up trucks or equipment without the help of a spotter using hand signals as per Swab Master Ltd **BACKUP PROCEDURE**. Spot Rig.
8. Perform a visual derrick inspection before raising the derrick.
9. Lay out matting as the swab rig must have good footing and stabilize the rig by lowering outriggers.
10. Hook-up ground and bonding cables.
11. If well is not shut-in, obtain and record flowing well pressure (as well as casing pressure if working on a tubing well) before shutting-in well to rig up.
12. At the directions of the oil company representative, shut-in the well by closing the “Master” valve, attach lockout tags and/or locks requested.
13. Opening & closing “Master” Valves.
14. When opening or closing master valves, always count the number of turns to ensure the valve is fully open or closed.
15. Always good practise to shout out the number of turns to other crew members so they are aware of the number of turns needed if they are the one operating the valve.
16. A master valve with a defined number of opening turns should close with the same number of turns. If when closing the valve, it feels closed with fewer turns, then there may be an obstruction in the valve body
17. Hand tools such as snipes or pipe wrenches must **NEVER** be used to assist closing the master valve.
18. If you are swabbing a low-pressure gas well with no Demco / Master Valve, refer to **SWABBING PROCEDURE – LOW PRESSURE GAS WELLS**
19. Bleed off any trapped gas pressure above the closed master valve by slowly sending the gas down an open flowline if possible. In cases where the flowline is under pressure, the wellhead will be equipped with a needle valve to allow the pressure to be released to the atmosphere. Stand on the up-wind side of the wellhead and carefully release the pressure to atmosphere. Ensure that the master valve is not leaking before removing the required wellhead equipment such as the bonnet, swage, or plunger lubricator.
20. Having the well shut-in and the surface equipment bled off provides a much safer workspace for raising the derrick.

CHANGING SWAB CUPS

GUIDELINES & INFORMATION

- When changing swab cups, all work is to be completed at ground level. It is important to maintain good communication and line of site between operator and assistant.

HAZARDS & CONTROLS

PRESSURE	Procedure Training; Pre-Job Safety Meeting; Caution; PPE
FIRE & EXPLOSION	Procedure Training; Detection & Control of Fire & Explosion Hazards Training; Pre-Job Safety Meeting; Caution; PPE
H2S	H2S Training; Procedure Training; Pre-Job Safety Meeting; Caution; PPE – Personal Gas Monitor; Respiratory Protection
PINCH POINTS	Procedure Training; Pre-Job Safety Meeting; Caution; PPE
EYE INJURY	Procedure Training; Pre-Job Safety Meeting; Caution; PPE – Eye Protection
EXTREME WEATHER	Pre-Job Safety Meeting; Communication; Weather Watch; Caution; PPE
SLIP / TRIP / FALL	Pre-Job Safety Meeting; Caution; PPE – Anti-Slip Steel Toes; Ice Grips



MUSCULOSKELETAL INJURY	Procedure Training; Pre-Job Safety Meeting; Frequent Breaks; Stretching
---------------------------	---

PROCEDURE

1. Remove the lubricator from the well (See Rig Out Procedure)
2. Lower the tool string to work at ground level. Ensure to keep your hands and body clear by standing off to the side while holding the outside of the lubricator
3. Remove bull nose from the mandrel. Ensure to loosen the set screw before removing.
4. Remove the old cups. Replace with new cups. The number of cups and configuration will be determined by the customer and the Rig Supervisor.
5. Replace the bull nose and tighten the set screw.
6. Ensure all persons are clear of the tool string.
7. Raise the tool string into the lubricator. **Have your assistant hold the outside of the lubricator while centering the cups as they enter the lubricator to avoid the cups catching the bottom of the lubricator, potentially damaging the cups.**
8. Pack off saver head and raise the lubricator and tool string together.
9. Using outriggers, re-center the lubricator over the well.
10. Lower the tool string until it enters the swedge and is sitting inside the swedge, just above the master valve. Center the tool string while doing this by holding the outside of the lubricator to keep the tool string centered.
11. Lower the lubricator onto the swedge ensuring it is level and straight.
12. Attach the lubricator to the swedge (Hammer union or Bowen union depending on lubricator setup).
13. Ensure saver head is packed off.
14. Open the master valve slowly to allow pressure to equalize.
15. Continue swabbing operations.

DERRICK RAISING / LOWERING

GUIDELINES & INFORMATION

- **Before** raising the derrick, a walk around inspection is required, including a look to the sky to ensure proper powerline clearance.
- Overhead Power Line and Electrical Safety:
 - We will never know the voltage of any given powerline during our workday. Therefore, a minimum of 7 meters of clearance **MUST** be kept between any powerline and Swab Master equipment. If a powerline is within the 7 meter clearance zone, stop operations, contact the customer representative, complete a new hazard assessment and contact ATCO Electric or Fortis Alberta for additional requirements. Reference the “Minimum Requirements for Unqualified Workers and/or Equipment Operating Near Overhead Power Lines” document for further information:

ATCO Electric 1-800-668-5506
Fortis Alberta 310-WIRE (9473)

MINIMUM REQUIREMENTS FOR UNQUALIFIED WORKERS AND/OR EQUIPMENT OPERATING NEAR OVERHEAD POWER LINES

Purpose: These minimum requirements are for your protection and safety. Contact with power lines is extremely dangerous and could result in death.

- 1) **Danger Zone** (unknown voltage) Equipment must **NOT** be operated within 7 m of any overhead power line without notifying ATCO Electric.
- 2) **Prohibited Area** (voltage confirmed by ATCO Electric)
 - a) No unqualified worker or equipment can enter the Prohibited Area.
 - b) ATCO Electric recommends all work within the 7 m Danger Zone, but outside the Prohibited Area require a designated signaller who can communicate by radio or air horn with all workers and equipment.
- 3) **NEVER ALLOW WORKERS OR EQUIPMENT TO ENTER THE PROHIBITED AREA!**
If work cannot be done outside the Prohibited Area contact ATCO Electric for assistance.
- 4) Work near power lines must be done during daylight hours only.
- 5) ATCO Electric recommends installing a minimum of two 50.8 cm x 71 cm "Danger Overhead Line" signs when operating equipment near the lines. (These can be purchased through most safety supply companies.) The signs must be installed on both sides of the line — at a height of 1.8 m and a distance of 7 m from the line. (Refer to the diagrams above.)
- 6) On-site workers must have a copy of the crossing agreement and all on-site personnel must be knowledgeable of its requirements.

Any violation could lead to sanctions under the OH&S Act and Regulation

IF YOU ACCIDENTALLY CONTACT AN OVERHEAD POWER LINE
— STAY CLEAR AND CALL ATCO ELECTRIC
1-800-868-5506

0205-0060-0314 March 2014, Revision 3

- Stay back at least 10 meters or 33 feet from any downed power line, exposed underground cable, or where there is contact with an overhead power line. Depending on voltage, this distance may increase up to 32 meters or 105 feet.
- Look up and check for overhead powerlines or obtain underground locates before beginning work. Always ask yourself – “WHERE’S THE LINE?”



- When operating the derrick in close proximity to power lines, always maintain the limits of approach: from 3 to 7 meters or 10 to 23 feet depending on voltage. For proper safe working distances contact Alberta Workplace Health and Safety at 1-866-415-8690. In keeping with the Alberta OH&S Code (Part 17 and Part 32), if equipment COULD come closer than the minimum distances, you must contact ATCO Electric before beginning work.
 - Stay at least 10 meters or 23 feet away from equipment operating near power lines because if it contacts and energized line, the electricity will go to the ground. The operator should be on the derrick with everyone else clear of the derrick with a boom is in motion. If you must approach, ensure the equipment is not operating.
 - If the derrick you are operating contacts an energized line, move it away from the line to break the contact. If this can't be done, remain on the machine. If there is an uncontrollable fire, jump of the machine keeping your feet together. Never contact the machine and the ground at the same time.
 - Shuffle or Hop, Don't Step Rule: Once clear of the machine, shuffle away, never allowing the heel of one foot to move beyond the toe of the other, or, hop with both feet together to a minimum distance of 10 meters or 33 feet.
 - The Alberta OH&S Code (Part 32) states that whenever digging or drilling is to occur, you must determine the location of all underground services. Call Alberta One Call before you dig at 1-8500-242-3447. If a cable is accidentally dug up, call ATCO Electric immediately at 1-800-668-5506. Move the digger bucket clear of the cable and stay out of the trench. If the machine can't be moved, keep workers 10 meters or 33 feet away and have the operator remain on the vehicle. In the case of fire, follow the 'Shuffle or Hop, Don't Step' rule.
 - Always call your local emergency services when someone is injured in an electrical accident. If they are still in contact with the electrical source and you touch them, you could be seriously injured or killed. Keep everyone back, a minimum of 10 meters or 33 feet and have someone call for help immediately.
 - Once you are sure contact with the power line has been broken by lowering the derrick and ensuring the area is safe, check co-workers for any potential injuries and administer First Aid as required.
 - Once contact is broken, do not move the equipment. Contact Swab Master management and Customer representative for further instructions. Swab Master management will travel to site and start an Incident Investigation. As per Swab Master Investigation Policy, all findings will be shared with all employees once completed.
- Any raising or lowering of a derrick in temperatures colder than -20 degrees Celsius or severe winds shall be discussed with the responsible Rig Supervisor or Senior Manager.
 - Prior to any raising or lowering, the mechanical equipment should be properly warmed up and function tested (hydraulic system, brake linkage, brakes).
 - Ensure that all locking or pinning locations are free from ice or obstruction.
 - A general visual inspection shall be done before raising or lowering and documented in the rig inspection sheet or book.
 - Ensure free movement of all sand lines.
 - Consideration should be given to wind direction and velocity prior to raising or lowering.
 - All operations shall cease when the environment of the personnel and equipment becomes hazardous.
 - All personnel should be positioned clear of any possible danger.
 - Lowering or rising of the derrick should be done in a slow, smooth, continuous operation.



- Note that in the structure and the raising mechanisms, the maximum loads occur at the initial lift off the crown rest.

RIGGING IN

1. Raise derrick as per Swab Master Ltd.
2. Align rig (lubricator) over well-center by raising or lowering each outrigger as needed.
3. Inspect rope socket and swivel before attaching appropriate tool string.
 - Inspecting the rope socket verifies the integrity of the first few meters of the sand line which can become “cats assed” from hard fluid tags or unexpected formation kicks. The swivel must function properly as the sand line will twist from stretching under load and must become relaxed to safely spool the line smoothly back onto the drum of the draw-works. The rope socket and swivel assembly **MUST** be inspected after any kick or abnormally hard fluid tag, at least once during a 12-hour shift and **no less than** daily.
4. If running a gauge ring or sinker bars for first run in the well, note and document these changes on the swab report as well as re-measuring the length of the tool-string and sketching a diagram of the gauge ring.
5. Always inspect wellhead threads. Confirm that threads are matching and in good condition. Clean and lube threads before installing swage and/or flow-tee and lubricator.
6. Attach lubricator and install an appropriately sized pressure gauge making it possible to monitor the wellhead pressure
7. ***Make sure all workers are off the rig deck area of draw-works and spooler while swabbing.***
8. Isolate the tool-string by lifting it above the 3-inch or 4-inch valve on the lubricator and closing it before opening the master valve in case excessive pressure has built up in the tubing while rigging up.
9. Open master valve with flowline closed and check for leaks. Record pressure. **ALWAYS** bleed off pressure prior to repairing any leaks. *Purge and pressure test with N2 if requested by oil company representative.*
10. Slowly open flowline valve to confirm unobstructed flow and to bleed off wellhead pressure. It may not be necessary on weak wells but closing the flowline prior to running into well with tool-string is recommended to help minimize the ability for the well to kick. Closely monitor for build-up of well pressure and adjust pack-off pressure to the saver-head as needed while running into well to prevent any fluid or gas from passing through the saver-head. Ensure unobstructed flow through the snot hose to allow gasses and fluids to escape to a containment tank.
11. Run tool-string into well at a rate of 180-210 meters/minute while closely monitoring string weight to determine the fluid level (fluid tag). Then, reduce speed dramatically to maintain string weight while proceeding to depth required to recover desired volume of fluid ... as agreed upon with the oil company representative. One cube of fluid per pull is a good rule of thumb.
12. Slowly open flowline and pull tool-string from well at a rate of **110-130 meters/minute maximum** until fluid reaches surface then reduce speed to approximately 50 meters/minute if swabbing casing or as high as 100 or greater while swabbing tubing. These retrieval speeds are guidelines but are very important. Pulling out of the well too fast can cause a vacuum effect below the swab mandrel, therefore causing an unnecessary increase in string weight as well as premature swab cup wear. Possible formation damage may result.

13. Swabbing Newly Fracked Wells – Swabbing Strat/Frac wells – use Guiberson mandrel with sand screen with 1 cup down, 3 cups up.



- Pull 50m of fluid each swab max, unless told otherwise by supervisor on location.
 - Check cups every swab for sand for first hour, if no sign of sand, check hourly. If sand is present, check cup for amount of sand every swab. Keep well site supervisor informed to determine if you should continue or stop swabbing.
 - If tools are stopped or hung up, proceed out of well and inform supervisor. Supervisor may want to make sinker bar run.
14. Do not stop in well to pack off – keep tools moving. Pack off once tools are moving in upward direction. Pack more as needed as fluid gets to surface.
15. When swabbing deviated well, do not go past 50° deviation.
16. **ALWAYS** have swab helper at the wellhead to operate the flowline valve as a choke to maintain string weight and eliminate the chances of becoming “kicked out” of the well.
17. Isolate the tool-string above the lubricator valve if necessary or once the well begins to flow.
18. Read and record all pressures, fluids recovered, fluid levels, fluid cuts, sand, or anything else found in fluid.
19. When swabbing 7” wells to 2” flowline, check cups and all tools every swab for the first hour. Pull 50m of fluid (1.0 m³) each swab maximum. When the fluid is at surface, slow down to 5m to 10 m/minute (keeping pressure under 400 Kpa) every swab for the first hour. Check the tool string every 6 hours.



RIGGING OUT

1. It is important to review with the helper the steps required to safely and efficiently rig off the well as some wells will load up with fluid very quickly and may become dead before you lay the derrick over. It may also be necessary for the oil company representative to divert the flowline from the status it was in while swabbing, therefore a brief tailgate meeting should be held to discuss next steps.
2. Have pipe wrenches pre-adjusted and wellhead equipment ready for quick install before proceeding and when ready, follow through with the following steps with no delays!
 - With master valve open, close flowline valve and quickly open valve on lubricator to allow any trapped fluid to drop down into the well.
 - Close master valve
 - While monitoring wellhead pressure, open flowline valve to bleed off trapped gas
 - Close flowline valve and observe pressure, which should be at zero
 - Uncouple union on bottom of lubricator off well center and over a drip tray. The helper can then safely remove the swage and/or flow-tee and re-install the wellhead equipment without being directly in line of fire below the lubricator.
3. Open master valve slowly and carefully purge wellhead if possible. Then **slowly** open flowline
4. Read and record flowing pressure
5. Remove lockout tags or locks
6. Unpin derrick, place lubricator, watch moving over-head equipment, lower derrick and secure for road
7. Pick up out riggers and matting. Clean all tools and store back in their proper place and ensure all is secure for travel.
8. Clean well-head and equipment (we try to keep clean of oil, water drops)
9. Slowly pull back to side of lease and park in safe spot
10. Finish off all orders and paperwork
11. Don't forget to thank them for the job and ask if they would like to see any changes in how the job, men or equipment can be improved.

RETURN TO BASE

- Return to base by using the same policies and procedures
- Fuel up and check tires
- Park back at shop using hand signals to a safe spot
- Do post trip inspections on trucks and equipment
- Repair or report damaged equipment for next use
- Leave trucks and shop in safe condition
- Drive home safe!

STUCK IN HOLE GUIDELINES RIG 9 & 15

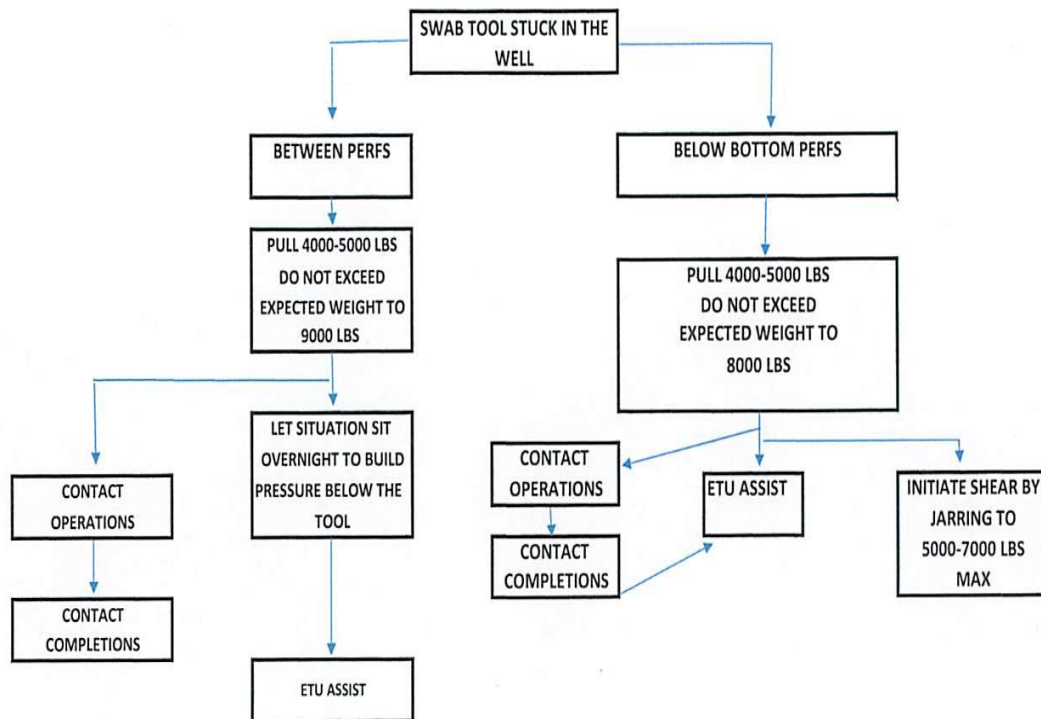



SWABBING PROCEDURE – FRACK WELLS

APPLICATION

Swabbing removes production fluid or hydrostatic pressure of a wellbore caused by fluid level and weight of hydrocarbons or production fluid in a string of tubing or casing in a completed well. The purpose of swabbing is to reduce wellbore pressure by physically pulling fluid out of the production string. When wellbore pressure is reduced, this could create a “kick” from the reservoir as the wellbore load is removed. This should initiate flow from the formation. A swabbing tool-string utilizes sand line and specially shaped swab cups which expand to seal against the tubing wall or casing and carry the liquids from the wellbore to the surface.

HAZARDS & CONTROLS

PRESSURE	Procedure Training; Pre-Job Safety Meeting; Caution; PPE
FIRE & EXPLOSION	Procedure Training; Detection & Control of Fire & Explosion Hazards Training; Pre-Job Safety Meeting; Caution; PPE
H2S	H2S Training; Procedure Training; Pre-Job Safety Meeting; Caution; PPE – Personal Gas Monitor; Respiratory Protection
PINCH POINTS	Procedure Training; Pre-Job Safety Meeting; Caution; PPE
EYE INJURY	Procedure Training; Pre-Job Safety Meeting; Caution; PPE – Eye Protection
EXTREME WEATHER	Pre-Job Safety Meeting; Communication; Weather Watch; Caution; PPE
SLIP / TRIP / FALL	Pre-Job Safety Meeting; Caution; PPE – Anti-Slip Steel Toes; Ice Grips
MUSCULOSKELETAL INJURY	Procedure Training; Pre-Job Safety Meeting; Frequent Breaks; Stretching

PROCEDURE

1. Complete a Pre-Job Safety Meeting to identify all hazards and implement appropriate controls.
2. Ensure Emergency Response Plan is in place
3. Review, discuss and make sure all attendees understand the following job details and well data.
 - Well depth
 - type of fluid in the tubing and annulus
 - anticipated fluid level and initial and anticipated well pressures
 - sweet gas or H2S
 - packers, plugs, bottom hole springs, collar stops, sliding sleeves
 - other in hole equipment
 - sand or wax problems in the past
 - type of swab tools and swab cups to be used ensuring the lubricator is the correct length and size to accommodate the tool string being used.
 - Maximum amount of fluid to be swabbed each pull per hour and
 - Maximum swab depth
4. Ensure that all surface equipment, the lubricator and BOP’s are pressure rated for the work that is being done
5. Make a sketch of the entire tool string noting the length and diameter of each piece. Include internal (ID) and outer (OD) diameters and the date of the drawing. This can be hand drawn but measurements **MUST** be accurate. Keep in the rig in case any tools are lost or become stuck in the well.
6. Walk around well-head and area (may have to move equipment to ensure that there is room for the swab rig and equipment).



7. Move rig to well-head. **NEVER** back up trucks or equipment without the help of a spotter using hand signals as per Swab Master Ltd **BACKUP PROCEDURE**. Spot Rig.
8. Perform a visual derrick inspection before raising the derrick.
9. Lay out matting as the swab rig must have good footing and stabilize the rig by lowering outriggers.
10. Hook-up ground and bonding cables.
11. If well is not shut-in, obtain and record flowing well pressure (as well as casing pressure if working on a tubing well) before shutting-in well to rig up.
12. At the directions of the oil company representative, shut-in the well by closing the “Master” valve, attach lockout tags and/or locks requested.
13. Opening & closing “Master” Valves.
14. When opening or closing master valves, always count the number of turns to ensure the valve is fully open or closed.
15. Always good practise to shout out the number of turns to other crew members so they are aware of the number of turns needed if they are the one operating the valve.
16. A master valve with a defined number of opening turns should close with the same number of turns. If when closing the valve, it feels closed with fewer turns, then there may be an obstruction in the valve body
17. Hand tools such as snipes or pipe wrenches must **NEVER** be used to assist closing the master valve.
18. If you are swabbing a low-pressure gas well with no Demco/Master Valve, refer to **SWABBING PROCEDURE – LOW PRESSURE GAS WELLS**
19. Bleed off any trapped gas pressure above the closed master valve by slowly sending the gas down an open flowline if possible. In cases where the flowline is under pressure, the wellhead will be equipped with a needle valve to allow the pressure to be released to the atmosphere. Stand on the up-wind side of the wellhead and carefully release the pressure to atmosphere. Ensure that the master valve is not leaking before removing the required wellhead equipment such as the bonnet, swage, or plunger lubricator.
20. Having the well shut-in and the surface equipment bled off provides a much safer workspace for raising the derrick.

DERRICK RAISING / LOWERING

GUIDELINES & INFORMATION

- Any raising or lowering of a derrick in temperatures colder than -20 degrees Celsius or severe winds shall be discussed with the responsible Rig Supervisor or Senior Manager.
- Prior to any raising or lowering, the mechanical equipment should be properly warmed up and function tested (hydraulic system, brake linkage, brakes).
- Ensure that all locking or pinning locations are free from ice or obstruction.
- A general visual inspection shall be done before raising or lowering and documented in the rig inspection sheet or book.
- Ensure free movement of all sand lines.
- Consideration should be given to wind direction and velocity prior to raising or lowering.
- All operations shall cease when the environment of the personnel and equipment becomes hazardous.
- All personnel should be positioned clear of any possible danger.
- Lowering or rising of the derrick should be done in a slow, smooth, continuous operation.



- Note that in the structure and the raising mechanisms, the maximum loads occur at the initial lift off the crown rest.

RIGGING IN

1. Raise derrick as per Swab Master Ltd.
2. Align rig (lubricator) over well-center by raising or lowering each outrigger as needed.
3. Inspect rope socket and swivel before attaching appropriate tool string.
 - Inspecting the rope socket verifies the integrity of the first few meters of the sand line which can become “cats assed” from hard fluid tags or unexpected formation kicks. The swivel must function properly as the sand line will twist from stretching under load and must become relaxed to safely spool the line smoothly back onto the drum of the draw-works. The rope socket and swivel assembly **MUST** be inspected after any kick or abnormally hard fluid tag, at least once during a 12-hour shift and **no less than** daily.
4. If running a gauge ring or sinker bars for first run in the well, note and document these changes on the swab report as well as re-measuring the length of the tool-string and sketching a diagram of the gauge ring.
5. Always inspect wellhead threads. Confirm that threads are matching and in good condition. Clean and lube threads before installing swage and/or flow-tee and lubricator.
6. Attach lubricator and install an appropriately sized pressure gauge making it possible to monitor the wellhead pressure
7. ***Make sure all workers are off the rig deck area of draw-works and spooler while swabbing.***
8. Isolate the tool-string by lifting it above the 3-inch or 4-inch valve on the lubricator and closing it before opening the master valve in case excessive pressure has built up in the tubing while rigging up.
9. Open master valve with flowline closed and check for leaks. Record pressure. **ALWAYS** bleed off pressure prior to repairing any leaks. *Purge and pressure test with N2 if requested by oil company representative.*
10. Slowly open flowline valve to confirm unobstructed flow and to bleed off wellhead pressure. It may not be necessary on weak wells but closing the flowline prior to running into well with tool-string is recommended to help minimize the ability for the well to kick. Closely monitor for build-up of well pressure and adjust pack-off pressure to the saver-head as needed while running into well to prevent any fluid or gas from passing through the saver-head. Ensure unobstructed flow through the snot hose to allow gasses and fluids to escape to a containment tank.
11. Run tool-string into well at a rate of 180-210 meters/minute while closely monitoring string weight to determine the fluid level (fluid tag). Then, reduce speed dramatically to maintain string weight while proceeding to depth required to recover desired volume of fluid ... as agreed upon with the oil company representative. One cube of fluid per pull is a good rule of thumb.
12. Slowly open flowline and pull tool-string from well at a rate of **50 meters/minute maximum** until fluid reaches surface then reduce speed to approximately 50 meters/minute if swabbing casing or as high as 100 or greater while swabbing tubing. These retrieval speeds are guidelines but are very important. Pulling out of the well too fast can cause a vacuum effect below the swab mandrel, therefore causing an unnecessary increase in string weight as well as premature swab cup wear. Possible formation damage may result.

13. Swabbing Newly Fracked Wells – Swabbing Strat/Frac wells – use Guiberson mandrel with sand screen with 1 cup down, 3 cups up.



- Pull 50m of fluid each swab max, unless told otherwise by supervisor on location.
 - Check cups every swab for sand for first hour, if no sign of sand, check hourly. If sand is present, check cup for amount of sand every swab. Keep well site supervisor informed to determine if you should continue or stop swabbing.
 - If tools are stopped or hung up, proceed out of well and inform supervisor. Supervisor may want to make sinker bar run.
14. Do not stop in well to pack off – keep tools moving. Pack off once tools are moving in upward direction. Pack more as needed as fluid gets to surface.
15. When swabbing a casing or tubing deviated well, do not go past 50° deviation. If there is no frac sand you can go up to 60° deviation, and under 1 cubic metre of fluid per swab. If you see any sand, run single cups and check cups after each swab. Stop swab if over 2% sand is present and contact manager.
16. **ALWAYS** have swab helper at the wellhead to operate the flowline valve as a choke to maintain string weight and eliminate the chances of becoming “kicked out” of the well.
17. Isolate the tool-string above the lubricator valve if necessary or once the well begins to flow.
18. Read and record all pressures, fluids recovered, fluid levels, fluid cuts, sand, or anything else found in fluid.



RIGGING OUT

1. It is important to review with the helper the steps required to safely and efficiently rig off the well as some wells will load up with fluid very quickly and may become dead before you lay the derrick over. It may also be necessary for the oil company representative to divert the flowline from the status it was in while swabbing, therefore a brief tailgate meeting should be held to discuss next steps.
2. Have pipe wrenches pre-adjusted and wellhead equipment ready for quick install before proceeding and when ready, follow through with the following steps with no delays!
 - With master valve open, close flowline valve and quickly open valve on lubricator to allow any trapped fluid to drop down into the well.
 - Close master valve
 - While monitoring wellhead pressure, open flowline valve to bleed off trapped gas
 - Close flowline valve and observe pressure, which should be at zero
 - Uncouple union on bottom of lubricator off well center and over a drip tray. The helper can then safely remove the swage and/or flow-tee and re-install the wellhead equipment without being directly in line of fire below the lubricator.
3. Unpin derrick, place lubricator, watch moving over-head equipment, lower derrick and secure for road
4. Pick up out riggers and matting. Clean all tools and store back in their proper place and ensure all is secure for travel.
5. Clean well-head and equipment (we try to keep clean of oil, water drops)
6. Slowly pull back to side of lease and park in safe spot
7. Finish off all orders and paperwork
8. Don't forget to thank them for the job and ask if they would like to see any changes in how the job, men or equipment can be improved.

RETURN TO BASE

- Return to base by using the same policies and procedures
- Fuel up and check tires
- Park back at shop using hand signals to a safe spot
- Do post trip inspections on trucks and equipment
- Repair or report damaged equipment for next use
- Leave trucks and shop in safe condition
- Drive home safe!

SWABBING PROCEDURE – HIGH PRESSURE & CRITICAL WELLS

APPLICATION

This subject outlines the information, operating procedure and equipment required for swabbing high pressure and critical rated wells.

HAZARDS & CONTROLS

Refer to **SWABBING PROCEDURE – GENERAL** for hazards and controls.

GUIDELINES & INFORMATION

1. Swabbing is done during daylight hours only unless there is sufficient lighting of the entire lease area to detect gas vapors. Before operations start, hold a pre-job meeting to discuss swabbing and shut-in procedures. Discuss a strategy for controlling the well in case it starts flowing.
2. Before and during swabbing, shut down all unnecessary engines and power sources 12v.

NOTE: Do not use the swab rig sand line to swab a well where the H₂S content exceeds 10%.

3. To eliminate fire hazards, the exhaust system should be either insulated or shielded and properly equipped with a spark arrester. Also, check that the engine emergency shutoff is working properly.
4. Assemble swab mandrels with swab cups for the string that is to be swabbed. (The swab cups should be steel core.) The mandrels are used in conjunction with sinker bars and a rope socket. A set of mechanical link-type jars should be run between the swab mandrel and the sinker bars to prevent tools from becoming stuck.
5. When swabbing in areas where H₂S concentration is 1% or greater:
 - A separator and flare stack is required for cleanup when the well starts to flow or in areas where potential hazards exist for onsite personnel or if an odour problem could be created for local residents, proper containment equipment must be installed (flare Stack & Separator)

NOTE: Approval for flaring H₂S gas may be required by the government regulatory body or permits.

6. When swabbing to a battery or a satellite:
 - Notify the operator, install a check valve on the flow line at the well, tag the manifold valve at the satellite or battery
7. When swabbing to a tank on the lease:
 - Flow through the contractor's pump line and manifold, control the flow at the manifold so that the withdrawal rate of the swabbing assembly does not exceed the spooling ability of the rig
 - If swabbing directly to a flow line and a manifold is not available, install a valve for flow control.
 - Check fire extinguishers for operating condition and place them at strategic locations on the lease. All ignition sources within 75m of the well and 75m of the rig tank must be eliminated.

All swab rigs shall be equipped with a minimum of two positive air breathing apparatus. In an H₂S area (where concentrations are 10 ppm or greater) fresh air breathing apparatus is required for each crew member. The apparatus must be used by all employees where a deficiency of oxygen may exist or where the atmosphere is contaminated or in danger of being contaminated by hazardous quantities of toxic gases or vapors. Breathing apparatus is not effective if worn over a beard.



PROCEDURE

1. Complete a Pre-Job Safety Meeting to identify all hazards and implement appropriate controls.
2. Ensure Emergency Response Plan is in place
3. Check well file and if there is or is not a packer in the well, leave the casing valve closed let no air in to wellbore
4. If gas vapors are settling around the well, discontinue swabbing until gas levels drop and it is safe to resume activity.
5. In H2S areas a lubricator designed to withstand H2S is required.

NOTE: the lubricator assembly would be considered minimum protection. It must be equipped with a bleed-off line and must be able to accommodate the total length of tools above the tool trap. The pressure rating of all fittings must be 3000 psi. All components must be serviced, inspected and hydro tested every three years.

6. Use a hydraulic BOP designed for use with a lubricator when working on gas wells or any wells difficult to control, i.e., where circulation is impossible and the well continues to flow.

NOTE: A flow tee connection must be installed below any lubricator unless the wellhead has been assembled and provides such a connection. When not used as a connection, it serves as an emergency pump-in connection.

7. **CAUTION:** The lubricator must be equal to or greater than ID of the tubing. If the ID is equal to the tubing, a fluid bypass must be installed above the flow tee.
8. Oil savers must be maintained in top condition and operated with hydraulic controls from the rig floor or ground level.
9. Valves through which tools travel must be full opening. Care must be taken when applying hydraulic pressure as rubbers wear quickly with excessive pressure.
10. A tool trap is recommended
11. A tool trap prevents dropped tools from falling to the bottom if the sand line is pulled from the socket after the socket hits the top of the lubricator. A tool trap can also indicate when tools are entering the lubricator.
12. *Pop-off saver heads are not to be used.*
13. Conventional tank trucks must not be used as swab tanks. When swabbing a slim hole completion, a shear sub must be used, and consideration should be given to using aluminum swab core swab cups
14. No more than .05 m³ of fluid should be pulled in any one run of the swab until a static fluid level is established.
15. Then up to 1.0M³ per swab can be pulled. As the well livens up, this amount should be reduced. Swabbing speed can be controlled by throttling the returns at the manifold. Set a collar stop when swabbing near the seating nipple or any tubing with reduced inside diameter. Swabbing is to be shut down at dark unless the lease is sufficiently illuminated.
16. Re-babbitt the rope socket before swabbing. (Refer to **POURING ROPE SOCKET PROCEDURE**)
17. Check the sand line, socket, swivel, cups, and mandrel size. Flag the sand line with three sets of flags in sequence of 3, 2, and 1, 25 m apart and check the condition of the line. Babbitt the line in the rope socket so that the swivel turns freely.
18. Check the cable spooling for overlapping of strands.
19. Workers must not stand in front of the sand line drum when the swab is being lowered or pulled, as the line might part or throw loops.
20. All swab rigs should have a mechanical sand line spooling device if mechanical spooling is required.
21. Manual spooling is not allowed.



- 22. Use only non-sparking material when spooling the sand line.
- 23. Before swabbing, pressure-test the lubricator to a pressure equal to the anticipated flowing wellhead pressure. (Refer to **HYDROSTATIC LUBRICATOR PRESSURE TEST**)
- 24. Knuckle joints should be run on certain directional wells (depending on deviation) and a knuckle joint will be required between sinker bars.
- 25. Take samples frequently to check for fluid properties.
- 26. Take wellhead readings as required.
- 27. *After the well starts to flow, discontinue swabbing.*
- 28. Check with the Rig Supervisor or a Manager for the recommended flow rate. Shut all the valves. Before removing the swab assembly, ensure that the master valve is closed and that the swab head and lubricator have been bled off and drained.
- 29. Record the result on the swabbing report.
- 30. If tools are lost in the tubing string, the risk of fishing must be weighed against that of killing the well and recovering the fish with the tubing string.

NOTE: The annulus, if on vacuum, may contain an explosive mixture after swabbing operations or after new completions or work overs. DO NOT attempt to take fluid levels with a well sounding instrument during this hazardous period unless a gas (CO2 or N2) gun is used.

SWABBING PROCEDURE – TUBING WELLS WITH ≤ 90 °C DOWNHOLE TEMPERATURE

APPLICATION

This subject outlines the information, operating procedure and equipment required for swabbing operations on well completed with 2-3/8 or 2-7/8" tubing where the maximum downhole temperature does not exceed 90 °C.

HAZARDS & CONTROLS

PRESSURE	Procedure Training; Pre-Job Safety Meeting; Caution; PPE
FIRE & EXPLOSION	Procedure Training; Pre-Job Safety Meeting; Caution; PPE
H2S	H2S Training; Procedure Training; Pre-Job Safety Meeting; Caution; Communication; PPE – Personal Gas Monitor, Respiratory Protection
PINCH POINTS	Procedure Training; Pre-Job Safety Meeting; Caution; PPE
EYE INJURY	Procedure Training; Pre-Job Safety Meeting; Caution; PPE – Eye Protection
EXTREME WEATHER (COLD & HEAT)	Pre-Job Safety Meeting; Communication; Weather Watch; Caution; PPE
SLIP / TRIP / FALL	Pre-Job Safety Meeting; Caution; PPE – Anti-Slip Steel Toes, Ice Grips
MUSCULOSKELETAL INJURY	Procedure Training; Pre-Job Safety Meeting; Caution; Frequent Breaks; Stretching
HIGH TEMPERATURE WELL FLUID	Procedure Training; Pre-Job Safety Meeting; Caution; PPE

GUIDELINES & INFORMATION

- 1. Maximum operating temperature for swab cups (TUF cups only), lubricator, and pressure control equipment: ≥ 90 °C.
- 2. Full PPE required: FR clothing, gloves appropriate for task, hard hat, goggles, CSA approved footwear, H₂S monitor (if applicable).
- 3. Emergency shut-in equipment (Master valve/BOP) must be installed, tested, and operational.
- 4. Designated fluid catchment and gas venting system (flare line or safe vent) must be in place.
- 5. Swab rig with calibrated line counter and weight indicator (Calibrated yearly).



6. Lubricator and master valve rated to well pressure.
7. Swab tool with cups rated $\geq 90^{\circ}$ C (**TUF CUPS**).
8. Pressure gauges on tubing and casing.
9. Fluid tanks for recovered fluids.
10. Communication devices (radio/headset) between rig crew and supervisor.

PROCEDURE

1. Conduct pre-job safety meeting with all affected personnel; assign roles and review emergency shut-in procedure.
2. Confirm well data: depth, fluid type, bottomhole temperature ($\leq 90^{\circ}$ C), expected pressures.
3. Conduct and document pre-use equipment inspections
4. Install lubricator on wellhead; pressure test (1000 PSI).
5. Verify sand line, sheave, and winch setup. Ensure all equipment is securely anchored.
6. Record initial tubing and casing pressures gauge.
7. Ensure Emergency Response Plan is in place
8. Prepare Swab Tool and ensure cups and tools are properly installed.
9. Run Tools in Hole
 - a. Run in swab tools slowly to target depth, just above perforations.
 - b. Monitor line tension to detect obstructions.
10. Swab Stroke
 - a. Pull swab tools upward at controlled speed (avoid rapid pulling).
 - b. Do not exceed 1m³ per swab
 - c. Bring tools into lubricator; shut in master valve.
 - d. Bleed off lubricator pressure into vent system.
11. Repeat Cycle
 - a. Swabbing back to depth.
 - b. Continue swabbing until:
 - i. Desired fluid volume is recovered, or
 - ii. Well begins to flow on its own, or
 - iii. Supervisor stops operation.
12. Monitoring
 - a. Record volumes of each swab stroke.
 - b. Monitor tubing and casing pressures continuously.
 - c. If well begins uncontrolled flow → close master valve and secure well immediately.
13. Post-Job
 - a. Record:
 - i. Total fluid recovered
 - ii. Pressures before, during, and after swabbing
 - iii. Well flowback characteristics
 - b. Inspect swab tools, cups, lubricator, and sand line for wear or damage.
 - c. Conduct post-job debrief and safety review.
 - d. Return well to safe operating condition and report to company representative.

SWABBING PROCEDURE – LOW PRESSURE GAS WELLS WITH NO DEMCO / MASTER VALVE

APPLICATION

Since older grandfathered wells have no Demco valve or Master Valve, additional safety precautions should be applied. Normal health and safety swabbing procedures must be followed with some exceptions.



HAZARDS & CONTROLS

Refer to GENERAL SWABBING PROCEDURE for hazards and controls.

Extreme CAUTION should be taken when removing the 4" - 2" swedge and installing or removing the flow tee. Pressure could be built up due to a potential mud plug in the well and / or a kick that could occur. The Rig Assistant (ground level helper) should NEVER have any part of their body over the opening of the well at any time. If the rare case of a kick occurring happens, pressurized debris will escape and cause injury.

PROCEDURE

- 1. Complete a Pre-Job Safety Meeting to identify hazards and implement control methods.
2. Tank truck hose should be connected to the 2" end of the 4" - 2" swedge and 2" ball valve to blow down the well prior to swabbing.
3. After the well has been blown down to the tank truck, close the 2" ball valve. The hose should then be unhooked and without hesitation reopen 2" ball valve.
4. Remove the 4" - 2" swedge and install a 4" Flow Tee
5. Connect the lubricator and swab the well as per the normal Swabbing Procedure - General
6. After swabbing is complete, disconnect the lubricator and lower it to ground level for the time being.
7. Install the 4" - 2" swedge, tighten and close the 2" ball valve.
- It is important to note that the well should not be open any longer than necessary.
- Close the well without delay.
8. Finishing rigging out and completing the job as per normal Swabbing Procedure - General.

SWABBING PROCEDURE - SLANT WELL

APPLICATION

Refer to SWABBING PROCEDURE - GENERAL for hazards and controls. This procedure is to be followed when completing a slant well operation. Slant Well Swabbing alleviates production fluid or hydrostatic pressure of a wellbore caused by fluid level and weight of hydrocarbons in a string of tubing or casing in a completed slant well.

The purpose of slant well swabbing is to reduce wellbore pressure by physically pulling fluid out of the production string. When wellbore pressure is reduced, this could create a "kick" from the reservoir as the wellbore load is removed. This should initiate flow from the formation. A swabbing tool-string utilizes sand line and specially shaped swab cups which expand to seal against the tubing wall or casing and carry the liquids from the wellbore to the surface.

HAZARDS & CONTROLS

Table with 2 columns: Hazard Type and Control Measures. Rows include PRESSURE, FIRE & EXPLOSION, H2S, PINCH POINTS, EYE INJURY, and EXTREME WEATHER (COLD & HEAT).



SLIP / TRIP / FALL	Pre-Job Safety Meeting; Caution; PPE – Anti-Slip Steel Toes, Ice Grips
MUSCULOSKELETAL INJURY	Procedure Training; Pre-Job Safety Meeting; Caution; Frequent Breaks; Stretching

PROCEDURE

1. Hold a PRE-JOB safety meeting. Be aware of other workers/contractors on lease and make sure they are included in your Pre-job safety. Make it known to all present if a young worker or new hand is on your crew. Discuss “ERP” (Emergency Response Plan) and hazard assessment. Sign “Safe Work Permit” and paperwork issued from oil company representative. Discuss the following job details with the oil company representative:
2. Review, discuss and make sure all attendees understand the following job details and well data.
 - Determine the chance of H2S
 - Look up for powerlines
 - type of fluid in the tubing and annulus
 - anticipated fluid level
 - initial and anticipated well pressures
 - well/tubing depths and depths of sliding sleeves, packers, plugs etc.
 - any previous sand or wax problems or concerns
 - recommended step of performing a gauge ring run to avoid becoming stuck in the well
 - type of swab cup(s) desired or the use of a sand screen
 - capacity of tank truck or catch tank and means of disposing the recovered fluid (Secure Energy, Aqua Terra, etc.) as well as any associated charges for flushing (cleaning) the tank if deemed necessary
3. Walk around wellhead area and move any obstructions to ensure that there is room for the swab rig and workers
4. Move rig to within three (3) meters from the wellhead keeping in mind the wellhead height and angle. Lower levelling jacks to ensure proper footing and raise derrick in accordance with Swab Master “Raising/Lowering Derrick Procedure”
5. Before raising the derrick, (Refer to **DERRICK RAISING / LOWERING**) a derrick inspection covering the following components must be performed.
 - hydraulic ram(s) – examine rod seals,
 - hoses and fittings for leakage or visible damage,
 - upper & lower ram pins and keepers
 - derrick pins and retainer clips, derrick locks
 - lubricator locks (if equipped)
 - lubricator lifters (kickers) – examine hydraulic rams pins & keepers
 - rod seals
 - hoses and fittings for leakage or visible damage.
 - Ensure that associated moving components are lubricated and move freely.
 - slant-arm(s) – pins & retainer clips, air rams, hoses, fittings etc.
 - saver-head relief hose fittings & unions, pack-off hose & quick coupler, U-bolt (yoke) & retainer clip
 - lubricator - hammer unions, plugs, external fittings, lifting-eye and support plate, winch line hook, hook latch, cable clamps and visual inspection of winch line for frays or bad kinks
6. With derrick in raised position... release lubricator locks (if equipped) and lower lubricator enough so that when the derrick is laid over the side-entry remains outside the structure of the derrick. This prevents the lubricator from catching on cross-members etc. when attempting to lower the lubricator with the derrick in the slant position.
7. Get all hand and down-hole tools needed set out and ready for use



8. Lower sand line to check rope socket and swivel, and then attach appropriate tool-string. The tool-string must have enough weight (sinker bars) to overcome the well pressure and friction pressure of the pack-off system (saver-head).
9. Ensure that the lubricator is the correct length and size to accommodate the tool-string being used.
10. Ensure that all surface equipment, the lubricator and BOP's are pressure rated for the work that is being done.
11. Lower derrick to travel position with lubricator locks engaged
12. Raise levelling jacks
13. Continue backing into spacing with help of a spotter using hand signals and park. The swab rig must be positioned square to the wellhead to ensure proper alignment of the derrick crown sheave with the lubricator and wellhead. Matting must be laid out prior to lowering levelling jacks as the swab rig requires good footing.
14. If a catch tank/tank truck is required, spot such in accordance with Swab Master "General Swabbing Procedure"
15. Open tank hatches and remove cap from degasser vent.
16. Lay out flowline
17. Hook-up ground bonding cables
18. Raise derrick to appropriate height (angle)
19. Lock derrick in place with slant-arm air cylinders (if equipped). If necessary, slightly raise/lower derrick to ensure both air cylinder rods are fully extended into the receiving alignment holes before proceeding
20. Lower winch-line and attach lubricator to wellhead. Adjust lubricator lifters (kickers) as needed to achieve required angle and provide adequate support for the weight of the lubricator.
21. Swab well in accordance with Swab Master "General Swabbing Procedure"
22. When complete – follow the rig out process in "General Swabbing Procedure"

TANK TRUCK PROCEDURE - GENERAL

APPLICATION

To ensure the safety of workers and prevent damage to equipment or the environment while recovering, handling and/or transporting wellbore fluids.

HAZARDS & CONTROLS

FIRE & EXPLOSION	Procedure Training; Pre-Job Safety Meeting; Caution; PPE
FALL FROM HEIGHT	Fall Protection Training; Procedure Training; Pre-Job Safety Meeting; Caution; PPE – Fall Arrest System (When going on top of the tank with no guards)
PRESSURE	Procedure Training; Pre-Job Safety Meeting; Caution; PPE
CHEMICALS	WHMIS Training; Procedure Training; Pre-Job Safety Meeting; MSDS; Caution; PPE
EYE INJURY	Procedure Training; Pre-Job Safety Meeting; Caution; PPE – Eye Protection
PINCH POINTS	Procedure Training; Pre-Job Safety Meeting; Caution; PPE – Eye Protection
SLIP / TRIP / FALL	Pre-Job Safety Meeting; Caution; PPE – Anti-Slip Steel Toes; Ice Grips
EXTREME WEATHER (COLD & HEAT)	Pre-Job Safety Meeting; Communication; Weather Watch; Caution; PPE

PROCEDURE

1. Perform Daily Tank Truck Inspection and document before leaving shop/yard
2. Check that proper PPE and equipment are worn and in good condition



3. Drive to location in accordance with **GENERAL DRIVING AND TRAVEL PROCEDURES**.
4. Participate in Pre-Job Safety Meeting, hazard assessment and understand the Emergency Response Plan (ERP)
5. Using Spotter position tank truck downwind from any other equipment, 50m from well center for a gas completion operation and in the southeastern part of Alberta the distance is only 35m for Prairie Shallow gas low impact completion operations. Make sure the tank is not blocking off lease access/exit. This should be planned during your pre-job safety meeting.
6. Turn off engine and any other electrical sources of ignition (clearance lights, etc.)
7. Open tank hatches, remove cap from degasser vent and be aware of which way the windsock is blowing.
8. Lay out flowline in accordance with Swab Master Hose Reel Procedure
9. Hook-up ground bonding cables
10. Personnel are not permitted inside the truck cab during any swabbing procedure.
11. Tank truck driver must monitor the levels in the tank at all times to prevent overflow or causing spills. All spills must be reported to on site consultant or lease operator. Tank dips are required to be done if there is no fluid level gauge on the tank. This will need to be done when the tank is considered half full being judged by the amount of fluid that is pulled by the swab rig and noted by the operator. Gas monitoring for H2S must be carried out as no employee can go up on the tank truck to do a dip if H2S is present.
12. Swab operator and or tank truck driver must alert the consultant on site that the tank is half full, so the consultant has time to arrange for the tank to be pumped off if that is the requirements determined by the consultants. If not, the tank truck driver must be prepared to take the tank truck to a facility to pump off fluids.
13. Upon completion of job... disconnect bonding cable and spool up flowline in accordance with Swab Master Hose Reel Procedure
14. Close tank hatches securely, replace cap on degasser vent.
15. Tank trucks that are crude spec do not have degassers
16. Ensure Fluid Transfer Form is filled out accurately and completely
17. Ensure labels and placards are in place
18. Dispose of recovered fluid as instructed by oil company representative or supervisor.
19. Clean and flush tank of mud, solids, or hydrocarbons if it was deemed necessary by the oil company representative.
20. Return to base by using the same policies and procedures
21. Park back at shop using hand signals to a safe spot
22. Do post trip inspections on trucks and equipment
23. Repair or report damaged equipment for next use
24. Leave trucks and shop in safe condition
25. Drive home safely

HOSE REEL PROCEDURE

APPLICATION

Using the hose reel spool on the back of the tank truck. Refer to the **TANK TRUCK PROCEDURE – GENERAL** for more information.

HAZARDS & CONTROLS

FIRE & EXPLOSION	Procedure Training; Follow Procedure Guidelines; Pre-Job Safety meeting; Caution; PPE
PRESSURE	Pre-Job Safety Meeting; Follow Procedure Guidelines; Caution; PPE
SLIP / TRIP / FALL	Pre-Job Safety Meeting; Caution; PPE – Anti-Slip Steel Toes, Ice Grips
PINCH POINTS	Procedure Training; Pre-Job Safety Meeting; Caution; PPE

PROCEDURE



1. Review the Pre-Job Safety Meeting to ensure all hazards are still identified and appropriate controls and emergency response plans are still valid.
2. Pace out 35m from well-head (up-wind if possible). Position tank truck.
3. Undo pin lock: ensure bypass is in open position. Pull out hose to the well. Use 2 people if necessary.
4. Secure hose reel after length is out with the lock pin.
5. To reel it back up, get back into the tank truck.
6. Start tank with clutch in, make sure you're in neutral flip the PTO switch on, release clutch easy.
7. Go to the back of the tank truck, turn valve handle to open and undo the spool pin lock.
8. Push in on lever to spool up, pull out to unreel.
9. Note: keep eye on chain tension and lubrication (keep half chick well-greased and bearings)



HOSE REEL OPERATIONAL SEQUENCE FOR TANK # 15 (GREEN UNIT)

Refer to TANK TRUCK PROCEDURE – GENERAL for hazards and controls.

PROCEDURE

- Step 1a) Start Truck (Turn the key ahead & push start button)
- Step 1b) Push in the clutch
- Step 2) While the clutch is engaged, put the PTO (Power Take Off) in “ON” position
- Step 3) Ensure holding speed selector is in slow position for few seconds to transfer hydraulic operation to the rear of the truck.
- Step 4) Ensure the hydraulic valve in the pump box is in operation mode and in the “ON” position
- Step 5) Release the hose reel pin
- Step 6) To release the hose and spool out: Ensure the valve by the hose reel is in hydraulic bypass position (Straight up and down)

SPOOLING THE HOSE ONTO THE REEL

- Ensure the hydraulic valve by the hose reel is in operation mode (side-ways)
- Be sure the hydraulic regulator spool speed is in a good position for spooling
- While keeping the hose in a nice tight spool, push the lever by the hose reel in spool on mode (feather accordingly)
- While performing this operation ensure that:
 1. All hands are far enough from the reel that they will not get pinched
 2. Be sure you have the proper footing
 3. Be sure the tail end of the hose is not caught or wrapped around anything and is ready for spooling
 4. Nice tight wraps on the hose reel
 5. Always watch for hose binding in the hose reel frame
 6. Once spooled, ensure the pin is in the lock position
 7. Ensure the hose is capped
 8. Secure the hose end to the hose reel frame
 9. Walk around the vehicle
 10. Ensure you document anything needing to be fixed
 11. Push in the clutch (engage)
 12. While the clutch is engaged, switch PTO to “OFF” position
 13. Walk around the unit to ensure everything is in “OUT/TRAVEL” mode
 14. Report any problems (leaks, broken items, etc...)

LOADING / UNLOADING TANK TRUCK PROCEDURE

APPLICATION

To ensure Swab Master Ltd. drivers, contractors and all equipment working on behalf of Swab Master Ltd. observe safety protection of the employee, environment and property while loading and unloading bulk fluids.

HAZARDS & CONTROLS

PINCH POINTS	Procedure Training; Follow Procedure Guidelines; Pre-Job Safety Meeting; Caution; PPE
MUSCULOSKELETAL INJURY	Pre-Job Safety Meeting; Caution; Frequent Breaks; Stretching
FIRE & EXPLOSION	Procedure Training; Follow Procedure Guidelines; Pre-Job Safety Meeting; Caution; PPE
FALL FROM HEIGHT	Fall Protection Training; Pre-Job Safety Meeting; Emergency Response Plan; PPE – Fall Arrest System
CHEMICALS	WHMIS Training; Pre-Job Safety Meeting; Follow Procedure Guidelines; Caution; MSDS; PPE
H2S	H2S Training; Procedure Training; Follow Procedure Guidelines; Emergency Response Plan; Caution; PPE – Personal Gas Monitor, Respiratory Protection
PRESSURE	Procedure Training; Pre-Job Safety Meeting; Caution; PPE
EXTREME WEATHER (COLD & HEAT)	Pre-Job Safety Meeting; Caution; Communication; Weather Watch; PPE

GUIDELINES & INFORMATION

Spill kits should be kept readily stocked and available
Ensure all tank vents are open prior to unloading

PROCEDURE

1. Complete a Pre-Job Safety Meeting to identify all hazards and implement appropriate controls.
2. Ensure Emergency Response Plan is in place
3. Prior to loading/unloading check with the operator /consultant or whoever may be in charge to make sure proper directions are understood.
4. Check tank gauges to make sure that proper volume can be handled.
5. Upon arrival at the loading/unloading facility, all Personal Protective Equipment must be worn.
6. Position your truck approximately 7 meters from loading/unloading facility.
7. Hook up the ground cable. (Make sure the cable has security to the ground).
8. Hook upload line. (If excessive pressure is expected, tie the cam-lock ears together).
9. Open the valves to the truck tank and production tank.
10. Keep close eye on gauges and floats. Do not assume that they are working properly.
11. When loading is complete, close the valve that is being used. (i.e.: loading would be the tank or vessel).
Close the tank valve first.
12. Cap off hose.
13. Disconnect your ground cable and place back onto your unit.
14. Make sure all valves are closed prior to departure.
15. Always keep loading /unloading areas neat and clean.

**Note: When you are finished loading/unloading make sure your process is in reverse to do the opposite.
* Do not leave your truck unattended at any moment while unloading /loading.**



TANK TRUCK WITH PUMP PROCEDURE

APPLICATION

Refer to TANK TRUCK PROCEDURE – GENERAL for hazards and responsibilities.

PROCEDURE

1. Make sure hatches, swabbing line and vent valves are locked open for the duration of the swab
IF H2S IS PRESENT DO NOT GO ON TANK UNLESS AIR PACKS ARE ON, refer to RESPIRATORY PROTECTION POLICY
2. Proper placards are on the tank in the proper spots
3. After swabbing ensure hatches & valves are closed, all lines are capped, wrapped up and tools put away
4. Off loading
5. Observe posted rules and regulations at lease entrance
6. Pull beside proper tank or inlet for offloading, apply brakes, and turn lights off
7. Examine, ground and bond cable then connect securely to bare metal
8. Open hatches on top of tank and air switch-controlled vent valve
9. Unstrap, uncap hose from tank truck and connect to desired tank inlet
10. There is usually fluid catchers to place under connections to save any mess being made
11. Open tank truck pump valves
12. Start pump on tank truck allowing it to suck a bit to dislodge sand that settled in the pump
13. Switch pump to off load making sure it is pumping off fluid
14. Open valve to tank being pumped to
15. Off load fluid, observe the whole process DO NOT leave the area
16. Close valve on tank being pumped to
17. Reverse tank truck pump
18. Disconnect hose from tank allowing pump to suck hose clean and re-cap
19. Shut valves on tank truck and switch pump off
20. Cap pump and hose then wrap & strap hose back on tank truck
21. Gather tools and put them away
22. Disconnect grounding cable
23. Clean any spilled fluid or mess
24. Close hatches on top of tank
25. Walk around the vehicle to ensure you are clear
26. Pull away from tanks if anyone else is waiting
27. Hand in fluid transfer sheet that is PROPERLY FILLED OUT!
28. PROPERLY FILL OUT new fluid transfer sheet with residue last contained
29. Head to next destination
30. Make sure rig operator gets a copy of fluid transfer to attach to the day's ticket

SPEC 2 TANK TRUCK WITH PUMP PROCEDURE

Refer to TANK TRUCK PROCEDURE – GENERAL for hazards and controls.

SWABBING

- Following Tank Truck Procedure, the Health and Safety Manual and,
- make sure hatches, swabbing line and vent valves are locked open for the duration of the swab
- IF H2S IS PRESENT DO NOT GO ON TANK UNLESS AIR PACKS ARE ON, refer to RESPIRATORY PROTECTION POLICY
- proper placards are on the tank in the proper spots
- after swabbing ensure hatches & valves are closed, all lines are capped, wrapped up and tools put away

UNLOADING PROCEDURE

1. Observe posted rules and regulations at lease entrance
2. Pull beside proper tank or inlet for offloading, apply brakes, and turn lights off
3. Examine, ground and bond cable then connect securely to bare metal
4. Open hatches on top of tank and air switch-controlled vent valve
5. Unstrap, uncap hose from tank truck and connect to desired tank inlet
6. There are usually fluid catchers to place under connections to save any mess being made
7. Open tank truck pump valves
8. Start pump on tank truck allowing it to suck a bit to dislodge sand that settled in the pump
9. Switch pump to off load making sure it is pumping off fluid
10. Open valve to tank being pumped to
11. Off load fluid, observe the whole process DO NOT leave the area
12. Close valve on tank being pumped to
13. Reverse tank truck pump
14. Disconnect hose from tank allowing pump to suck hose clean and re-cap
15. Shut valves on tank truck and switch pump off
16. Cap pump and hose then wrap & strap hose back on tank truck
17. Gather tools and put them away
18. Disconnect grounding cable
19. Clean any spilled fluid or mess
20. Close hatches on top of tank
21. Walk around the vehicle to ensure you are clear
22. Pull away from tanks if anyone else is waiting
23. PROPERLY FILL OUT new fluid transfer sheet with residue last contained
24. Head to next destination
25. Make sure rig operator gets a copy of fluid transfer to attach to the day's ticket

PREPARATION OF TANK TRUCKS PROCEDURE

APPLICATION

Preparation of Tank Trucks for Pre-Welding and/or Inspections.

HAZARDS & CONTROLS

Refer to TANK TRUCK PROCEDURE – GENERAL for hazards and controls.

PROCEDURE

1. Check that your proper PPE and equipment are worn and in good condition.
2. Open or remove ALL tank truck hatches or blanks (these are to remain off until welding is completed)
3. Blow out hose reel and or load lines
4. Take tank truck to approved disposal site such as Secure, Aqua Terra etc.
5. Dispose of any remaining fluid, sand, or mud.
6. Flush tank thoroughly
7. If tank has hauled oil etc. chemical de-greaser should be used to degrease all areas of tank.
8. If hydrocarbons are still present in the tank, steaming will be necessary.
9. Once thoroughly cleaned all valves should be closed, i.e.: load lines, pump-lines and hose-reel lines.
10. Tank is to be tested with gas monitor using an external sampling attachment. This will allow testing on tank floor, corners and top for any gases or hydrocarbons that maybe trapped. (Gas monitor is to be bump tested and have an up-to-date calibration prior to using.)



11. When taking the tank truck to the welding shop, **make sure that the welding shop is aware of the fact that the tank truck is used in the Oil & Gas industry, and they must do their due diligence and safety checks prior to commencing work on the unit.**
12. Do not remain in the welding area of shop during repairs.

TOOL RETRIEVAL / WIRE ROPE (STUCK IN WELL PROCEDURE)

APPLICATION

Methods for recovering Sand line and tools that are stuck in the well. Refer to **GENERAL SWABBING PROCEDURE** for more information.

HAZARDS & CONTROLS

PRESSURE	Procedure Training; Pre-Job Safety Meeting; Caution; PPE
FIRE & EXPLOSION	Procedure Training; Pre-Job Safety Meeting; Caution; PPE
SLIP / TRIP / FALL	Pre-Job Safety Meeting; Caution; PPE – Anti-Slip Steel Toes, Ice Grips
H2S	H2S Training; Procedure Training; Pre-Job Safety Meeting; Caution; Communication; PPE – Personal Gas Monitor, Respiratory Protection
PINCH POINTS	Procedure Training; Pre-Job Safety Meeting; Caution; PPE
EYE INJURY	Procedure Training; Pre-Job Safety Meeting; Caution; PPE – Eye Protection
EXTREME WEATHER (COLD & HEAT)	Pre-Job Safety Meeting; Communication; Weather Watch; Caution; PPE
MUSCULOSKELETAL INJURY	Procedure Training; Pre-Job Safety Meeting; Caution; Frequent Breaks; Stretching
BURNS	Procedure Training; Pre-Job Safety Meeting; Caution; PPE

PROCEDURE

1. Complete a Pre-Job Safety Meeting to identify all hazards and implement appropriate controls.
2. Ensure Emergency Response Plan is in place
3. Review the following job details:
 - type of fluid in the tubing and annulus
 - anticipated fluid level
 - initial and anticipated well pressures
 - depths
 - Check available well and downhole data to ensure that the proper tool type and size are run.
4. Ensure that the lubricator is the correct length and size to accommodate the tool string being used.
5. Install on wellhead two hydraulic type annular BOP's in tandem with lower BOP designed with the kill and flow ports. The upper BOP is for back-up purposes only.
6. The tool string must have enough sinker bars to overcome the well pressure and friction pressure of the pack-off system (saver-head)
7. If catch tank required, spot tank 50m from wellhead, keeping in mind:
 - the wind direction
 - the lay of the land
 - other workers (contractors) that may be conducting work on the same location
 - lease access for tanker trucks etc.
- DO NOT block-off lease entrance/exit with line pipe or flow line hose for obvious reasons.**
8. Back rig up to proper distance from wellhead. Always use a spotter.
9. Hook up ground and bonding cables.
10. Record initial tubing and casing pressures.
11. Attach appropriate tool, inverted cup, and run into hole to determine fluid level and top of sand line. Pull out of hole.



12. Hold safety meeting to discuss safe approach to retrieve line and tools, factors such as anticipated pressures, overall weight expected to lift tools and fluid.
13. With flow line closed and dead weight attached to monitor gas build-up, run in hole with fishing tool as directed by company representative.
14. If successful at catching line, slowly pull up to a maximum pull as specified by company representative. **(NEVER ALLOW TOOL STRING TO BE LOWERED TO AVOID LOSING ACHIEVED BITE).**
15. Once latched onto line and tools are moving up hole proceed to retrieve dead sand line and tools until dead sand line is observed at surface.
16. Close lower annular and bleed off any pressure present in lubricator through flowline.
17. Close flowline for appropriate time to determine proper closing of annular/BOP. If gas pressure builds, close second annular/BOP.
18. Disconnect lubricator, place hole cover around line on top of BOP.
19. Attach appropriate sand line, hoisting clamp(s) and rest clamp on hole cover.

USING HAND TOOLS AT HEIGHTS PROCEDURE

APPLICATION

How to properly secure hand tools and use at heights safely.

HAZARDS & CONTROLS

PRESSURE	Procedure Training; Pre-Job Safety Meeting; Caution; PPE
PINCH POINTS	Pre-Job Safety Meeting; Caution; PPE
EYE INJURY	Pre-Job Safety Meeting; Caution; PPE – Eye Protection
SLIP / TRIP / FALL	Pre-Job Safety Meeting; Caution; PPE – Anti-Slip Steel Toes; Ice Grips
MUSCULOSKELETAL INJURY	Procedure Training; Pre-Job Safety Meeting; Proper lifting techniques

GUIDELINES & INFORMATION

Dropped or unsecured objects at heights continue to present significant safety challenges in operational activities. Dropped objects are among the top 3 Causes of death and serious injury across many industrial sectors. While there is no regular maintenance performed at heights on Swab Master Ltd. equipment, should an emergency happen that requires the use of tools at height, proper tethering and transporting from ground to height is required for safety. The Rig Operator is responsible for Dropped Object prevention on site.

- Identify new Scope of Work. Communicate to all personnel on site of work being done overhead and the area below is to be clear of all personnel until task is complete.
- Wear fall protection, along with proper PPE- Hard Hat, FR coveralls, task specific gloves, safety glasses, ice cleats if required
- Select only the tools required to do the job and place them in a designated weight load limit canvas closing pail with one end of length appropriate rope attached to the pail and the other end secured to your person. Inventory of tools and equipment (bolts etc.) must be documented before and upon completion of task to ensure nothing is left at height.
- Climb ladder using 3-point contact, leaving pail of tools at the base of the ladder.
- Once on top of the doghouse with feet planted securely and fall protection harness securely attached, pull pail of tools up and secure.
- Attach wrist strap to wrist of selected tool, grip and remove from bucket. Once finished with tool, place back in bucket and remove wrist strap from wrist. Repeat with each tool until job is complete. If a tool is attached with a tether, clip the other end of tether strap to a D ring on your fall protection harness



- Close bucket and lower to bottom of ladder. Unhook fall protection, and using 3-point contact, climb down the ladder

Important Safety Tips

- Do not unsecure tool from yourself until it is back in the bucket
- Tether must be attached to one person at all times. If handing tool to another worker, both must be tethered before one worker releases his tether
- Always inspect tethers, straps and ropes for proper load weights and condition before using
- Any near misses or incidents need to be reported to supervisor and an opportunity report filled out

WASH BAY PROCEDURE

APPLICATION

To ensure the safe work practices of all employees utilizing the wash bay and the awareness of possible hazards. Rig Units, Tank Trucks and Pickup Trucks can be washed in the wash bay area.

Depending on the unit you are washing you must pay strict attention to the following procedures.

HAZARDS & CONTROLS

FALL FROM HEIGHT	Fall Protection Training; Procedure Training; Pre-Job Safety Meeting; Caution; PPE – Fall Arrest System (When going on top of the tank with no guards)
PRESSURE	Procedure Training; Pre-Job Safety Meeting; Caution; PPE
SLIP / TRIP / FALL	Pre-Job Safety Meeting; Caution; PPE – Anti-Slip Steel Toes, Ice Grips
FIRE & EXPLOSION	Procedure Training; Pre- Job Safety Meeting; Caution; PPE
CHEMICALS	WHMIS Training; Procedure Training; Pre-Job Safety Meeting; MSDS; Ventilation; Caution; PPE
EYE INJURY	Procedure Training; Caution; PPE – Eye Protection
H2S	H2S Training; Procedure Training; Pre-Job Safety Meeting; Communication; Caution; PPE – Personal Gas Monitor, Respiratory Protection
NOISE	Pre-Job Safety Meeting; Caution; PPE – Hearing Protection
MUSCULOSKELETAL INJURY	Procedure Training; Caution; Frequent Breaks; Stretching

PROCEDURE

BEFORE ENTERING THE WASH BAY:

1. Close any open hatches on tanks.
2. Ensure propane tanks are removed
3. Turn on the ventilation system
4. Ensure hoses re wrapped up.
5. Have a spotter in clear view guiding driver safely into wash bay area
6. Ensure you have PPE on i.e.: safety goggles, oil/chemical resistant boots, gloves, rain suit
7. When using chemicals – Check the MSDS (SDS) to determine the hazards of the product and what protective equipment will be necessary.
8. Ensure ventilation fan is turned on
9. Set up mobile ladder or fall protection if it will be needed.
10. Ensure the Emergency Response Plan is in place before starting work

NEVER aim the hose at anyone for any reason. This will result in disciplinary action.

PREPARING & WASHING THE UNIT

1. Turn unit off
2. When possible, leave bay door open to vent possible fumes and to allow clearer visibility



3. Ensure all other workers who are not part of the task are clear of the wash area
4. Ensure all PPE is on for the task i.e.: proper goggles, oil/chemical resistant boots, gloves, rain suit
5. Ensure you are using the right chemicals and avoid all skin contact
6. When mixing chemicals be aware of splashes
7. Read the information on your MSDS sheets about proper use and safe procedures of all chemicals used.
8. If working above height of 3m, workers must wear a 5-point harness attached to approved lanyard and overhead fall arrest anchor as per the **FALL PROTECTION POLICY**
9. Visually inspect wash pump hoses and electrical cords before starting
10. Ensure that other workers are at a proper distance rated for pressure from pump
11. Ensure that other workers are not in direct line of power wash gun before turning on
12. Avoid contact with light fixtures and electrical receptacles
13. Avoid direct contact with air filter components and radiator fins
14. When washing be aware of your footing
15. Always keep a firm grip on the hose or spray nozzle. Do not pull the trigger until you are in proper position
16. Watch for any obstacles which could cause slips, trips, falls
17. Completely wash unit spraying in a downward motion when possible
18. If you are working alone follow the **COMMUNICATIONS & WORK ALONE POLICY** and make sure a supervisor is aware you are completing the task alone

RETURN THE UNIT TO OUTSIDE FLEET POSITION

1. If washing in winter, dry unit before leaving the wash bay area.
2. Ensure wash bay door is fully open to accommodate the height of the unit
3. Do a walk around Before backing outside to ensure hoses and obstacles have been placed in their proper spot
4. Use a spotter to safely back unit from wash bay and park outside
5. Inspect vehicle to ensure none of the components of the unit have been loosened or damaged by spray
6. Re-grease any areas that require greasing Re-lubricate drive chain (Refer to **EQUIPMENT MAINTENANCE PROCEDURE**)

WASH BAY CLEAN UP

The wash bay is to be kept clean and ready for the next person to use it:

1. Properly clean floors walls and remove other debris.
2. All chemicals are put back to proper location
3. Inform a supervisor or manager:
 - if any wash supplies are depleted or running low
 - if the wash bay is found unclean
 - if there are any issues with the wash bay or equipment.

TO DO OUTSIDE

1. Take off propane tanks
2. Weather permitting, tank hatches are open to vent any possible gas fumes outside
3. Ensure hoses are wrapped up
4. Walk around unit to make sure no obstructions are in your way

WINTER WASHING

1. Always remove propane bottles
2. Avoid water contact on brake components and linkages
3. Ensure all chemicals are completely washed off
4. Ensure all water is dried and drained from units before parking outside



WAX KNIFE PROCEDURE

APPLICATION

Mechanically de-waxing tubing wells – Wax Knife. The Wax Knife is attached to the tool string to cut and loosen wax build-ups or hydrates formed on the I.D. of tubing wells. The wax cutter is a spear shaped tool with a series of cross holes drilled in a spiral pattern the length of the tool. Appropriate size and desired stiffness of wire is then placed through each hole and bent around the body. The wire ends are then twisted together to form what looks like a pigtail. This twist is then cut off to a measured length suited for the I.D. of the tubing that the tool is to be used in.

HAZARDS & CONTROLS

PRESSURE	Procedure Training; Pre-Job Safety Meeting; Caution; PPE
PINCH POINTS	Procedure Training; Pre-Job Safety Meeting; Caution; PPE
H2S	H2S Training; Procedure Training; Pre-Job Safety Meeting; Communication; Caution; PPE – Personal Gas Monitor, Respiratory Protection
FIRE & EXPLOSION	Procedure Training; Pre-Job Safety Meeting; Caution; PPE
CHEMICALS	WHMIS Training; Procedure Training; Pre-Job Safety Meeting; MSDS; Caution; PPE
MUSCULOSKELTAL INJURY	Procedure Training; Pre-Job Safety Meeting; Caution; Frequent Breaks; Stretching

PROCEDURE

1. Complete a Pre-Job Safety Meeting to identify all hazards and implement appropriate controls.
 2. Ensure Emergency Response Plan is in place
 3. Review the following job details:
 - type of fluid in the tubing and annulus
 - anticipated fluid level
 - initial and anticipated well pressures
 - Check available well and down hole data to ensure that the proper tool type and size are run
 4. Ensure that the lubricator is the correct length and size to accommodate the tool string being used.
 5. Ensure that all surface equipment, the lubricator and BOP's are pressure rated for the work that is being done.
 6. The tool string must have enough sinker bars to overcome the well pressure and friction pressure of the pack-off system (saver-head)
 7. If catch tank required, spot tank 50m from wellhead, keeping in mind:
 - the wind direction
 - the lay of the land
 - other workers (contractors) that may be conducting work on the same location
 - lease access for tanker trucks etc.
- DO NOT block-off lease entrance/exit with line pipe or flow line hose for obvious reasons***
8. Back rig up to proper distance from wellhead. Always use a spotter.
 9. Hook up ground and bonding cables.
 10. Shut-in well, attach and label lockout tags as required.
 11. Count the number of turns required to close the master valve and ensure that it is not leaking. Always inspect wellhead threads to see if they match properly with type being used, clean and lube before rigging in with lube.
 12. Record initial tubing and casing pressures.
 13. Attach wax knife to tool string.
 14. Rig into wellhead and attach flow line to catch tank.
 15. Before running the tool string into the well, make a sketch of the total tool string, noting the length, as well as the internal (I.D.) and outer (O.D.) diameters.
 16. Lower the wax knife down the tubing, exceeding the depth that wax characteristically forms in the well.

17. After each pass a provision should be made to flow or circulate loose wax from the well.
18. Remove the tool string to surface to clean the wax cutter and the tool string after each pass. Install new cutting wires as needed.
19. Open well to tank to let flow which will assist in cleaning wax from well bore.
20. Regular swabbing may proceed once wax has been removed.
21. Upon completion, read and record casing and tubing pressures.
22. Rig off wellhead.
23. Remove lockout tags and put well back online or as instructed.

Wax Knife

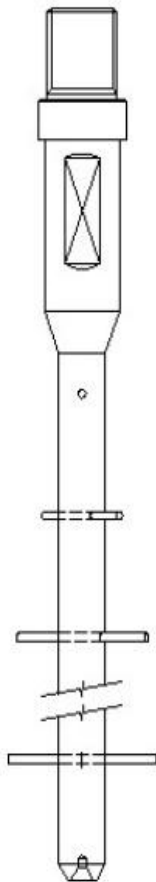

PURPOSE

Cut and loosen wax build ups formed on the I.D. of the tubing walls.

DESCRIPTION

The wax cutter is a spear shaped tool with a series of cross holes drilled in a spiral pattern the total length of the body.

Wire is then placed through each hole and bent around the body.

Twist the wire ends together to form what looks like a pigtail.

This twist is then cut off to a measured length suited for the I.D. of the tubing, the wax cutter will be used in.

OTHER APPLICATIONS

Loosening hydrates forming on the I.D. of the tubing walls.

OPERATION

Install the wax cutter on a tool string and lower down the tubing string, exceeding the depth that wax characteristically forms in the well or area.

After each pass a provision should be made to flow or circulate loose wax from the well.

To avoid getting the tool string stuck on wells with heavy wax or hydrates passes, should be shortened to a few meters then pulling up and clearing worked area with tool string.

Remove the tool string to surface to clean the wax cutter and the tool string after each pass.

PRECAUTIONS

Install new cutting wires regularly.

Nominal Size		0.75"	1.50"
Assembly Number		0101WK075A0	0101WK150A0
Item	Part Name		
1	Wax Knife	0101WK07501	0101WK15001
Upper Thread Connection		0.500 - 13 UNC	0.938"-10 UN
Fishneck size		0.75"	1.187"



WELDING EQUIPMENT PROCEDURE

APPLICATION

For safe use of welding equipment for general use.

HAZARDS & CONTROLS

PRESSURE	Procedure Training; Pre-Job Safety Meeting; Caution; PPE
FIRE & EXPLOSION	Procedure Training; Pre-Job Safety Meeting; Caution; PPE
SLIP / TRIP / FALL	Pre-Job Safety Meeting; Caution; PPE – Anti-Slip Steel Toes, Ice Grips
NOISE	Procedure Training; Pre-Job Safety Meeting; Caution; PPE – Hearing Protection
PINCH POINTS	Procedure Training; Pre-Job Safety Meeting; Caution; PPE
EYE INJURY	Procedure Training; Pre-Job Safety Meeting; Caution; PPE – Eye Protection
EXTREME WEATHER (COLD & HEAT)	Pre-Job Safety Meeting; Communication; Weather Watch; Caution; PPE
MUSCULOSKELETAL INJURY	Procedure Training; Pre-Job Safety Meeting; Caution; Frequent Breaks; Stretching
BURNS	Procedure Training; Pre-Job Safety Meeting; Caution; PPE

MAINTENANCE & EQUIPMENT CHECK BEFORE THE TASK

Ensure that before welding starts, an inspection of a reasonable area surrounding the welding operation is carried out and that combustible, flammable and explosive material, dust, gases, or vapors that are present or likely to be present in the work location are identified. Steps must be taken to ensure that such materials are not exposed to ignition by taking one or more of the following actions:

1. have the combustible, flammable and explosive material, dust, gas, or vapor, or the sources of these, moved a safe distance from the work location
2. have the combustible, flammable and explosive material, dust, gas, or vapor properly shielded against ignition
3. have the work moved to a location free from combustible, flammable and explosive material, dust, gas, or vapor
4. schedule the welding operation so that such combustible, flammable and explosive material, dust, gas, or vapor is not exposed during welding and cutting operations, and
5. other effective methods that will render the area safe.

GUIDELINES & INFORMATION

1. Inspect all tools before using such as defective cables or electrode holders.
2. Use a continuous gas detector where possible to detect toxic or flammable vapors.
3. Consider other workers before striking an arc.
4. Do not weld while standing in water.
5. Never weld near gas pipes or gas chambers.
6. Use adequate, approved ventilation or approved respirator while welding in confined spaces and restricted spaces or when working on zinc, brass, bronze, stainless steel, galvanized, or lead coated materials.
7. Keep combustible materials out of welding area.
8. Keep a fire extinguisher handy.
9. Protect combustible materials with fire blankets or non-flammable guard.
10. Do not wear jewellery on the job.
11. Handle compressed gas cylinders carefully (see compressed gas cylinders procedure)
12. Do not use a cutting torch as a hammer.
13. Do not weld on vessel or pipe that had not been properly cleaned of all flammable vapors.
14. Keep area clear of hoses and cables.
15. When leaving the area, turn off gas cylinders first, and then turn off torch after bleeding hoses.
16. Never heat an object lying flat on a concrete floor.



- 17. ONLY authorized persons shall operate welding equipment. New or used electrodes shall not be left lying on floors, walkways, or where they may cause a hazard.
- 18. Welding screens shall be used where practical to prevent other persons from being exposed to the welding arc.
- 19. Shut off welding machine when stopping work for any appreciable length of time.

WR (WIRELINE RETRIEVAL) PLUG PROCEDURE

APPLICATION

Plug Retrieval – Removing wireline retrieval plug from well. Refer to the **SWABBING PROCEDURE – GENERAL** for more information.

HAZARDS & CONTROLS

PRESSURE	Procedure Training; Pre-Job Safety Meeting; Caution; PPE
FIRE & EXPLOSION	Procedure Training; Pre-Job Safety Meeting; Caution; PPE
CHEMICALS	WHMIS Training; Pre-Job Safety Meeting; MSDS; Caution; PPE
PINCH POINTS	Pre-Job Safety Meeting; Procedure Training; Caution; PPE
MUSCULOSKELETAL INJURY	Pre-Job Safety Meeting; Procedure Training; Manual Material Handling Policy; Caution; Frequent Breaks; Stretching

PROCEDURE

1. Review the pre-job safety meeting to ensure the hazards are identified and proper controls are implemented, and the emergency response plan is still valid.
2. Review the following job details:
 - type of fluid in the tubing
 - anticipated fluid level
 - initial and anticipated well pressures
 - Check available well and downhole data to ensure that the proper tool type and size are run.
3. record starting pressures,
4. attach hydraulic jars to toolstring
5. measure tool string length and diameter,
6. ensure enough lubricator length to accommodate toolstring and plug.
7. Attach appropriate type and size of pulling tool and ensure you have done a sketch drawing of the tool
8. Run into hole at a constant speed
9. Stop above target, note weight indicator, and let toolstring settle out
10. Continue to target depth at a reduced speed and land firmly on top of the plug with the retrieval tool.
11. Pull up a little over string weight to ensure a good latch on the plug then hit down lightly to open equalizing ports (increase weight of strikes if needed).
12. Pressure on well will rise if open or go on vacuum if fluid was used to provide showing the ports open. If they do not open repeat step 10.
13. Give time for well to equalize
14. Jar up to unseat plug and continue out of hole. Keep in mind slips on plug may become latched on collars.
15. Slow down going through master valve.
16. Close master valve

WILDLIFE PROCEDURES

GENERAL WILDLIFE SAFETY

Some wildlife may look tame but they're not. They are wild animals. Be cautious no matter when or where you see wildlife. Keep at least 3 bus lengths (30 metres or 100 feet) away from large animals and keep about three times that distance away from bears.

Never feed wildlife of any sort. It is bad for the animal and could be bad for your health. By exposing yourself to wild animals, you are at risk to come in to contact with rabies or tick-related diseases. Animals that become used to being fed by people lose their natural fear instinct and may become aggressive.

Always be aware of the native wildlife in the area you will be working. In our home base region, the most exposure will be to elk or rattlesnakes, with a slight chance of exposure venomous spiders. However, with rampant forest fires, we may see movement of bears or cougars in the area that have been displaced.

Don't forget the little ones! Rodents may not be a danger to your physical safety, but the diseases they carry can infect you and affect your health. Bites from poisonous or venomous insects and reptiles may also affect your health.

RATTLE SNAKES

Snakes are important members of the natural world and make a significant contribution to the control of pests such as rats, insects, and other snakes. Poisonous snakes, however, are not desirable members of the human habitat. The risk of a poisonous snakebite is lower than that of being struck by lightning and can be reduced further by:

- Cleaning up refuse and other hiding spots around buildings and yards
- Wearing heavy shoes and pants in wooded areas; and
- Looking first before stepping or touching hidden areas where snakes are likely to be resting or hiding.
- Leather chaps are available for employees if they are required.

Rattlesnakes in the Alberta belong to the pit viper group. The pit viper has pits on its head, vertical pupils, a triangular head, slim neck, and a heavy body with a single row of scales on the underside of the tail. The pit viper group includes the two major categories of rattlesnake. All pit vipers may vibrate their tail sections rapidly to make noise when threatened.

Rattlesnake: There are many varieties of rattlesnakes that have pit viper characteristics and a button on the tail (youngest snakes), plus two to four segments of rattles for each year of age. The size range of rattlesnakes is 15 to 72 inches, with the record size held by a 96-inch Eastern Diamondback.

IF YOU ARE BITTEN BY A SNAKE

If the snake is still in the area, do not attempt to kill or catch it, unless it poses a danger to you or the victim. Try to remember what it looks like so you can identify the type of snake from pictures in the emergency room. Remove all items that may restrict circulation in the affected extremity. Watches, bracelets, rings, gloves, or shoes may pose a problem as the bite area swells.

Immobilize the affected area as much as possible. Attempt to keep the bite at or slightly below the level of the head. If swelling occurs rapidly, place a 1-inch-wide constricting band about 2 inches above the bite. This is not a tourniquet and should not fit so tightly you cannot easily slip a finger under it. Do not place a constricting band on a joint.

Attempt to keep the victim from moving rapidly about while transporting him/her to the nearest emergency medical facility as quickly as possible.

- Note:
- a. Do not Give the victim anything to eat or drink, particularly alcohol;
 - b. Do not Place the affected area in ice;
 - c. Do not Make any cuts or apply suction to the area;
 - d. Do not Attempt to give anti-venom; or suck the venom out
 - e. Do not administer pain or anti-anxiety medications



SAFETY PRECAUTIONS WITH SNAKES

After a flood, storms, snakes are forced into places where they usually are not found. Take the following precautions if you work in an area where poisonous snakes are common.

- ✓ Know how to identify poisonous snakes common to your area.
- ✓ Be alert for snakes in unusual places. They may be found in or around homes, barns, outbuildings, driftwood, levees, dikes, dams, stalled automobiles, piles of debris, building materials, trash, or any type of rubble or shelter.
- ✓ Search the premises thoroughly for snakes before beginning any cleanup or rescue operations. Snakes may be under or near any type of protective cover.
- ✓ If you kill a poisonous snake, use a stick, rake, or other long-handled tool to carry the snake away for disposal. Snakes may bite even when they appear dead.
- ✓ If you realize you are near a snake, avoid sudden movement, which may cause the snake to strike. If you remain still the snake may leave. If the snake doesn't move away from you slowly back away from it.
- ✓ If someone is bitten by a poisonous snake, call 911 immediately.

Be sure to report any snake sightings to the Safety Coordinator as a near miss using an opportunity report form. If there is any injury from a rattlesnake, it must be reported immediately using an incident reporting form.

CERVIDAE MAMMALS (DEER FAMILY)

When we speak of animals falling under the “cervidae family” you should think of horns and hooves. Animals associated with this classification are:

- Elk - Deer - Moose - Caribou

While only some of these species are native to Southern Alberta, several accounts of displaced animals have been recorded in the area. Most times animals will avoid human contact as much as possible, but on occasion, there may be a close encounter.

One potential threat of coming too close to these breeds is attacks. Females (cows or does) are more aggressive in the late spring to early summer seasons when they have their calves. Males are more aggressive during mating season, in the fall. The animals in this category will attack if they feel cornered or they are provoked.

SIGNS OF AN AGGRESSIVE ANIMAL THAT MAY ATTACK

- Walking in your direction
- Stomping its feet
- Peeling back its ears
- Grunting
- Throwing its head back and forth



TIPS TO PREVENT OR SURVIVE AN ATTACK

- Back away with your palms facing the animal
- Speak softly and reassuringly, like you would a small child
- If the animal does charge, try to get behind something that will separate your body from the animal like a tree or rock. Most times, when these animals charge, it is a bluff.
- If you cannot avoid attack, feign death by curling up into a ball. Protect your head and neck with your arms.
- If you are witnessing the attack, call 911 if you think there is physical injury to the person being attacked.

Be sure to report any wildlife sightings to the Safety Coordinator as a near miss using an opportunity report form. If there is any injury from any animal, it must be reported immediately using an incident reporting form.



RODENTS

Most rodents do not pose any significant safety hazard to humans; however, they are carriers of several diseases that can be spread to humans via the droppings or saliva of the animal. Some of the most severe diseases are listed and all rodents should be treated as potential carriers. Refer to the section on page 18 under the Chemical, Biological and Harmful Substances Information Policies section for more information on handling rodents.

HANTAVIRUS – DEER MICE

The only confirmed carrier of the Hantavirus in Alberta is the deer mouse (reddish-brown or in some cases grey, but always with white fur on the underside of the neck, belly, feet, and tail). However, it is possible that other rodents may carry the virus, and it is not always easy to determine what kind of mouse one is exposed to (particularly when the only evidence is droppings). The virus does not appear to have any effect on mice which carry it.

PLAGUE – ROCK SQUIRRELS, PRAIRIE DOGS, GROUND SQUIRRELS AND CHIPMUNKS

Plague is a bacterial infection, and humans usually get plague after being bitten by a rodent flea that is carrying the plague bacterium or by handling an animal infected with plague. Without prompt treatment, the disease can cause serious illness or death. Symptoms include fever and chills, extreme weakness, abdominal pain, diarrhea and vomiting, bleeding from your mouth, nose, or rectum, or under your skin, shock or blackening and death of tissue (gangrene) in your extremities, most commonly your fingers, toes and nose.

LYMPHOCYTIC CHORIO-MENINGITIS (LCM) – COMMON MOUSE

LCM is a neurological disease caused by breathing in dust that is contaminated with rodent urine or droppings, direct contact with rodents or their urine and droppings or bite wounds, although this does not happen frequently. The initial phase of infection can be a flu-like illness. Following a few days of recovery, the second phase of the disease occurs. This may include fever, headache, nausea, vomiting, stiff neck, confusion, drowsiness, and paralysis.

TULAREMIA – MUSKRATS, GROUND SQUIRRELS, BEAVERS, RABBITS & HARES

Tularemia is a bacterial illness that ranges from mild to life-threatening. The signs and symptoms of tularemia vary depending on how the bacteria enter the body. All forms are accompanied by fever, which can be as high as 104 °F. Other symptoms may include sudden fever, chills, headaches, diarrhea, muscle aches, joint pain, dry cough, and progressive weakness

INSECTS

If you have known allergies to insect stings or bites – you must inform the office to keep this record on file.

MOSQUITOS

West Nile (WN) virus is a mosquito-borne virus. Mosquitoes transmit the virus after becoming infected by feeding on the blood of birds which carry the virus. For most Canadians, the risk of illness from West Nile virus is low, and the risk of serious health effects is even lower. Nevertheless, it is important to know the symptoms of illness related to infection and how to minimize your risk, especially if virus activity is reported in an area near you.

BEES & WASPS

It is important to be prepared for any possible effects from an insect sting, whether it happens at work or at home. Generally, most stings will only result in a temporary injury - pain, swelling, and skin redness around the sting. However, sometimes the effects can be more severe - even life-threatening, depending on where you are stung and what allergies you have.

If you are stung in the throat area of your neck, it may cause edema (swelling caused by fluid build-up in the tissues) around the throat and may make it difficult to breathe.

Remember, if you are startled or stung by a bee or wasp while you are driving, working with power tools or machinery, or are on a ladder, you could end up getting injured with much more than a sting!

NORTHERN SCORPION

In Canada, the northern scorpion is found only in the very dry and hot valleys of BC, Alberta and Saskatchewan. This little critter is your typical small, blondish scorpion, but no more dangerous to humans than bees or wasps. Their venom is mild, but allergic reactions are possible from any venom.

SPIDERS

Hazardous spiders that are native to our area include the black widow and the brown recluse (violin or fiddler spider). Both bites are treatable. Symptoms of both spider bites are severe pain at bite site after about four hours, severe itching, nausea, vomiting, fever, and myalgia (muscle pain). ***If left un-treated the brown recluse bite can lead to necrosis and the black widow venom may lead to paralysis or death.***



BLACK WIDOW



BROWN RECLUSE

GIANT WATER BUG

The Giant Water Bug is a common inhabitant of ponds, marshes and slow moving waterways. When an unsuspecting aquatic insect or small vertebrate (frog, tadpole or small fish) swims to close the Bug seizes it with its hooked front legs and plunges its beak into the prey's body, injecting digestive fluids. A short while later the prey's innards are liquefied and the Bug sucks out the "soup" leaving an empty husk. Giant Water Bugs can fly and are attracted to light. Caution should be used when handling them as ***they can inflict a painful bite.*** It is Alberta's largest aquatic insect.



FIRE AND EXPLOSION HAZARD MANAGEMENT

Training on Fire and Explosion Hazard Management is provided for all employees of Swab Master Ltd. It is part of the general orientation for Swab Master Ltd. Any employee wishing to learn more about this topic is offered to take the Detection and Control of Flammable Substances course through any local safety training company.

UNDERSTANDING THE CAUSE OF FIRE & EXPLOSION – THE FIRE TRIANGLE

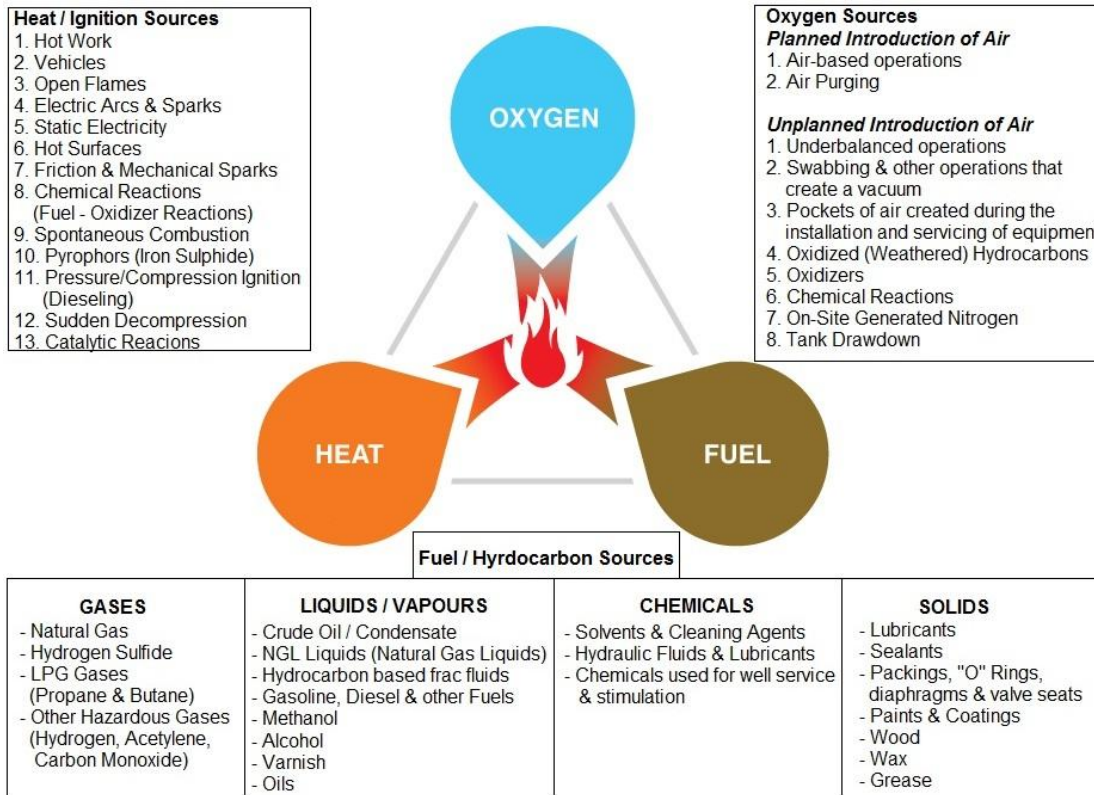

Oxygen: Fire needs air to breathe and grow. Approximately 16% needed. Normal air contains 21% O₂. Some fuel materials contain sufficient oxygen within their make-up to support burning.

Heat / Ignition: There are many sources that can cause a fire or explosion by reaching the ignition temperature. For example, open flame, hot surfaces, sparks and arcs, friction, chemical action, electrical energy, and the compression of gases.

Fuel: There are different types of fuel that can cause and sustain a fire. The table above describes such types. All flammable substances stored or used at the work area (lease or shop) will:

1. Be stored in only CSA approved containers.
2. Not be in sufficient quantity to create an explosive atmosphere if accidentally released.
3. Not be stored within 30 meters of an underground shaft.
4. Not be stored near the air intake of:
 - a) A ventilation supply system.
 - b) An internal combustion engine or;
 - c) The fire box of a fired heater or furnace.

There are 3 key points that must be remembered:

1. Anytime all three sides of the fire triangle co-exist, there is a real potential for a fire or explosion.
2. There are 8 critical risk factors that increase the probability of a fire and explosion significantly.
3. The system is dynamic, and circumstances change over time. As a result, safe situations may become unsafe



PREVENTION – FIRE & EXPLOSION CONTROLS

Many Fire & Explosion incidents are the result of failure to recognize potential hazards. The figures on the next page show where many hazards could exist that are related to fuel, oxygen and ignition sources. Pre job safety meetings will be done at EVERY lease for EVERY job.

Pre-Job Safety Meeting Report
Remember Why We Work and Play Safe - It's Our Families!

Location: _____ Date: _____ Unit #: _____ Job or Service Ticket #: _____ Multi-Services: Y N

Swab Master Representative: _____ Client Representative: _____

Company: _____

Description of Work To Be Performed: _____

General Topics Discussed (All Employees on Site)

<input type="checkbox"/> Designated Safety Meeting Area(s)	<input type="checkbox"/> Ground Conditions	<input type="checkbox"/> Vehicle Access	<input type="checkbox"/> Others:
<input type="checkbox"/> Adequate Lighting	<input type="checkbox"/> Fire Extinguishers	<input type="checkbox"/> Hot Work Permits	<input type="checkbox"/> Confined Space (a) _____
<input type="checkbox"/> PPE is being worn (As Designated)	<input type="checkbox"/> Work Area / Lease Conditions	<input type="checkbox"/> Derrick Inspection	<input type="checkbox"/> JSA Required (b) _____
<input type="checkbox"/> Smoking Area Identified	<input type="checkbox"/> MSDS Sheets Location	<input type="checkbox"/> LEL Bump Test	<input type="checkbox"/> JSA Required (c) _____
<input type="checkbox"/> Wireline Hazards	<input type="checkbox"/> LEL Bump Test		
<input type="checkbox"/> Lockout/Tag-out (If Applicable) Lock #1 _____	<input type="checkbox"/> Lock #2 _____	<input type="checkbox"/> Lock #3 _____	

Hazard Identification (Check if hazards then proceed to pre-job hazard assessment if medium to high hazard)

<input type="checkbox"/> 1. Overhead Power Lines	<input type="checkbox"/> 9. Working Alone / Remote Location	<input type="checkbox"/> 18. Noise
<input type="checkbox"/> 2. Buried Cables	<input type="checkbox"/> 10. Hazardous Energy Sources	<input type="checkbox"/> 19. Inadequate Lighting
<input type="checkbox"/> 3. Congested Area	<input type="checkbox"/> 11. Rotating / Unguarded Equipment	<input type="checkbox"/> 20. Working at Heights
<input type="checkbox"/> 4. Pinch Points	<input type="checkbox"/> 12. Radioactive Material / Norm	<input type="checkbox"/> 21. Suspended Loads
<input type="checkbox"/> 5. Hydrogen Sulfide	<input type="checkbox"/> 13. Weather Hazards	<input type="checkbox"/> 22. Overhead Lines
<input type="checkbox"/> 6. Worn or Damaged Equipment	<input type="checkbox"/> 14. Environmental Hazards / Spills	<input type="checkbox"/> 23. Others: _____
<input type="checkbox"/> 7. Chemicals / Hydrocarbons / Caustics / Acids / Hot Oil	<input type="checkbox"/> 15. Respiratory Hazards / Toxic Vapors	(a) _____
<input type="checkbox"/> 8. Explosives	<input type="checkbox"/> 16. High Pressure	(b) _____
	<input type="checkbox"/> 17. Poor Housekeeping / Slippery Surfaces	

Hazard #	Risk Level	Steps to Eliminate Hazards & Reduce Risks	Residual Risk	Who (If Applicable)

Fire and Explosion Hazards (Identify components of the fire triangle that could be present)

<input type="checkbox"/> Energy and Ignition	<input type="checkbox"/> Oxygen and Air
<input type="checkbox"/> Fuels and Hydrocarbons	

<p>Level of Risk (Identify)</p> <p><input type="checkbox"/> Improbable Fire triangle does not exist</p> <p><input type="checkbox"/> Possible Fire triangle may exist No risk factors present</p> <p><input type="checkbox"/> Probable Fire triangle may exist One or more risk factors present</p>	<p>Critical Risk Factors (Identify factors that could be present)</p> <p><input type="checkbox"/> Liquid Hydrocarbons</p> <p><input type="checkbox"/> H₂S</p> <p><input type="checkbox"/> Oil based workover fluids</p> <p><input type="checkbox"/> High pressure or temperature</p> <p><input type="checkbox"/> Rapid pressure or temperature changes</p> <p><input type="checkbox"/> Flow into closed system</p> <p><input type="checkbox"/> Pre-existing trapped air</p> <p><input type="checkbox"/> Mixing of products or chemicals</p>
<p>Procedures Required</p> <p><input type="checkbox"/> Alertness for failure of barriers or controls that would affect FEHM</p> <p><input type="checkbox"/> Reusable hazard management plan</p> <p><input type="checkbox"/> Detailed, site-specific hazard management plan</p> <p><input type="checkbox"/> Documented risk assessment</p>	

Fire and Explosion Controls (What is being done to prevent fire triangle from forming?) _____

Emergency Controls (What is the response if conditions change?) _____

Print Name	Signature	Print Name	Signature
1. _____	_____	4. _____	_____
2. _____	_____	5. _____	_____
3. _____	_____	6. _____	_____

To the best of our knowledge, all known onsite hazards have been identified, eliminated and controlled.

This Report Will Be Posted At All Times During Operation.

Emergency Numbers
Swab Master Ltd. Office: 1-403-793-0033 • Stars Emergency Link: 1-888-888-4567 or *4567 • Emergency Dispatch: 911
STARS Satellite Phone Link: 1-403-299-0932

White - Attach to Service Ticket Yellow - Client Company Pink - Swab Master Ltd. Operator GRAY GRAPHICS LTD. - TLELEY, AB

Swab Master Ltd. does not operate internal combustion engines in hazardous locations; however, the following methods of control will be used if that event arises:

Internal combustion engines in a hazardous location will:

1. Have a combustion air intake and exhaust discharge that are:
 - a) Equipped with a flame arresting device or;
 - b) Located outside the hazardous area
2. All surfaces of an internal combustion engine that are exposed to the atmosphere in a hazardous location are:
 - a) At a temperature lower than the temperature that would ignite a flammable substance present in the hazardous location or.
 - b) Shielded in such a way as to prevent any flammable substance in the area from contacting the surface.

SWAB MASTER LTD. – HEALTH & SAFETY MANUAL / EL 3: HAZARD CONTROL - PROCEDURES Page - 91 -

LIST CONTROLS IN PLACE TO ENSURE WORKER & EQUIPMENT SAFETY:

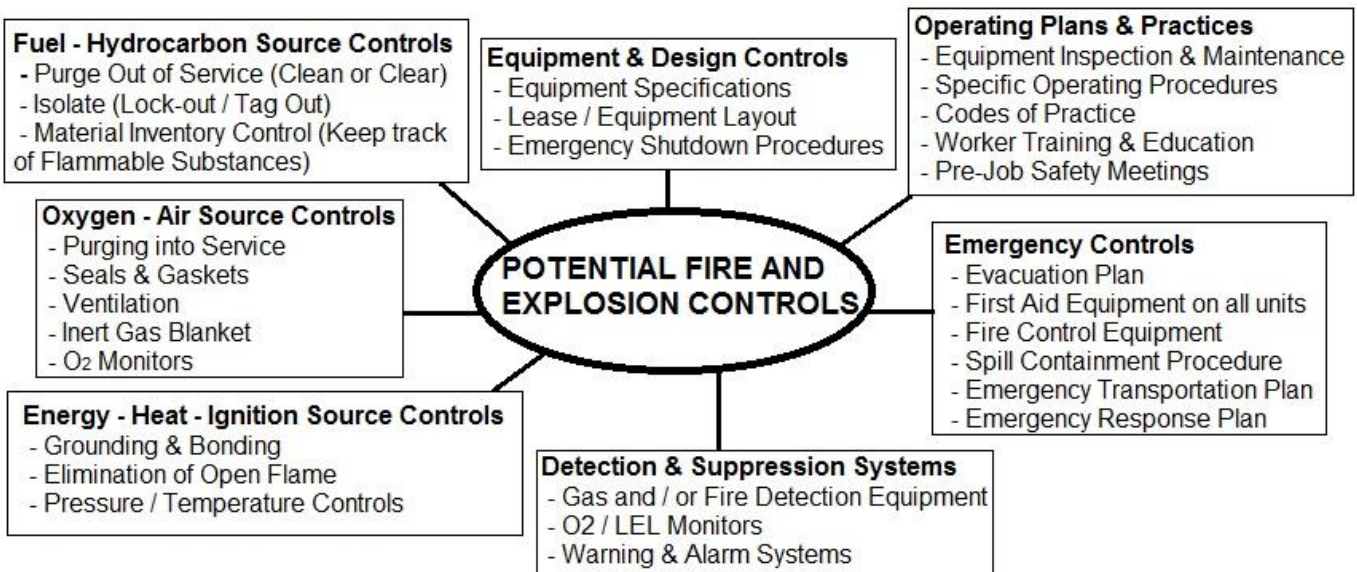
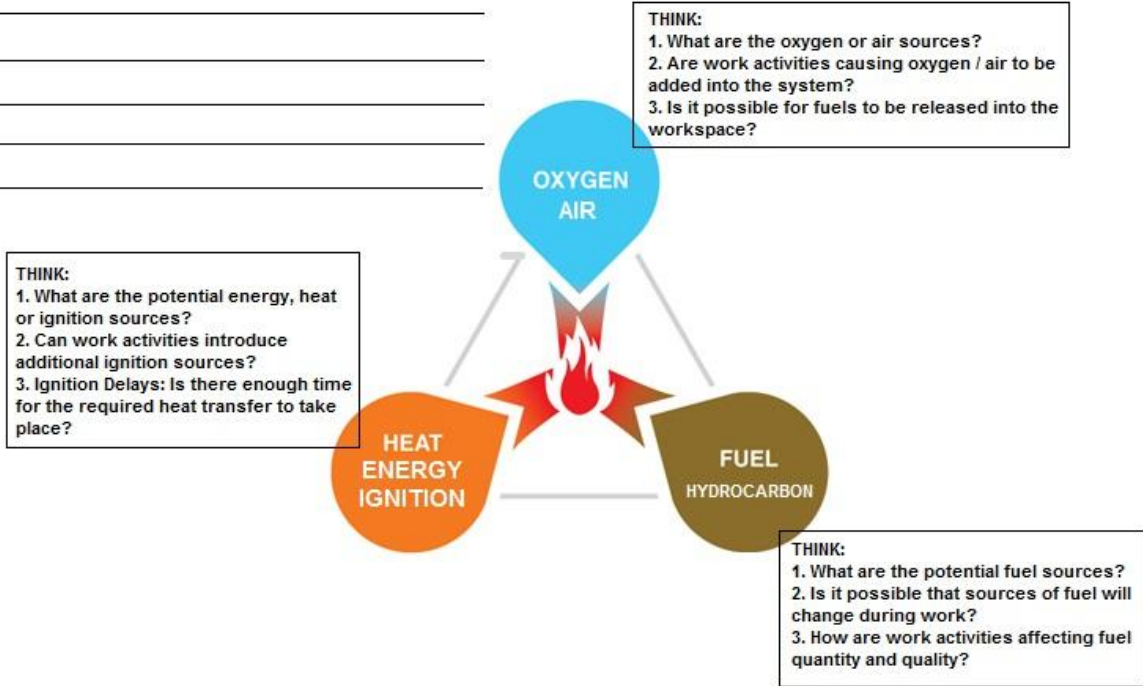

In the Emergency Response Plan (ERP) there is a Fire & Explosion procedure for the Head Office at 479 Aquaduct Drive, Brooks, AB. Evacuation and emergency procedures are included.

FIRE & EXPLOSION HAZARD MANAGEMENT PROCESS – HOW TO IMPLEMENT THE STAGES INTO EVERY JOB

Stage 1: Assess – Do a Pre Job-Safety Meeting for each job at each location to determine different hazards that may exist or present themselves during the scope of work.

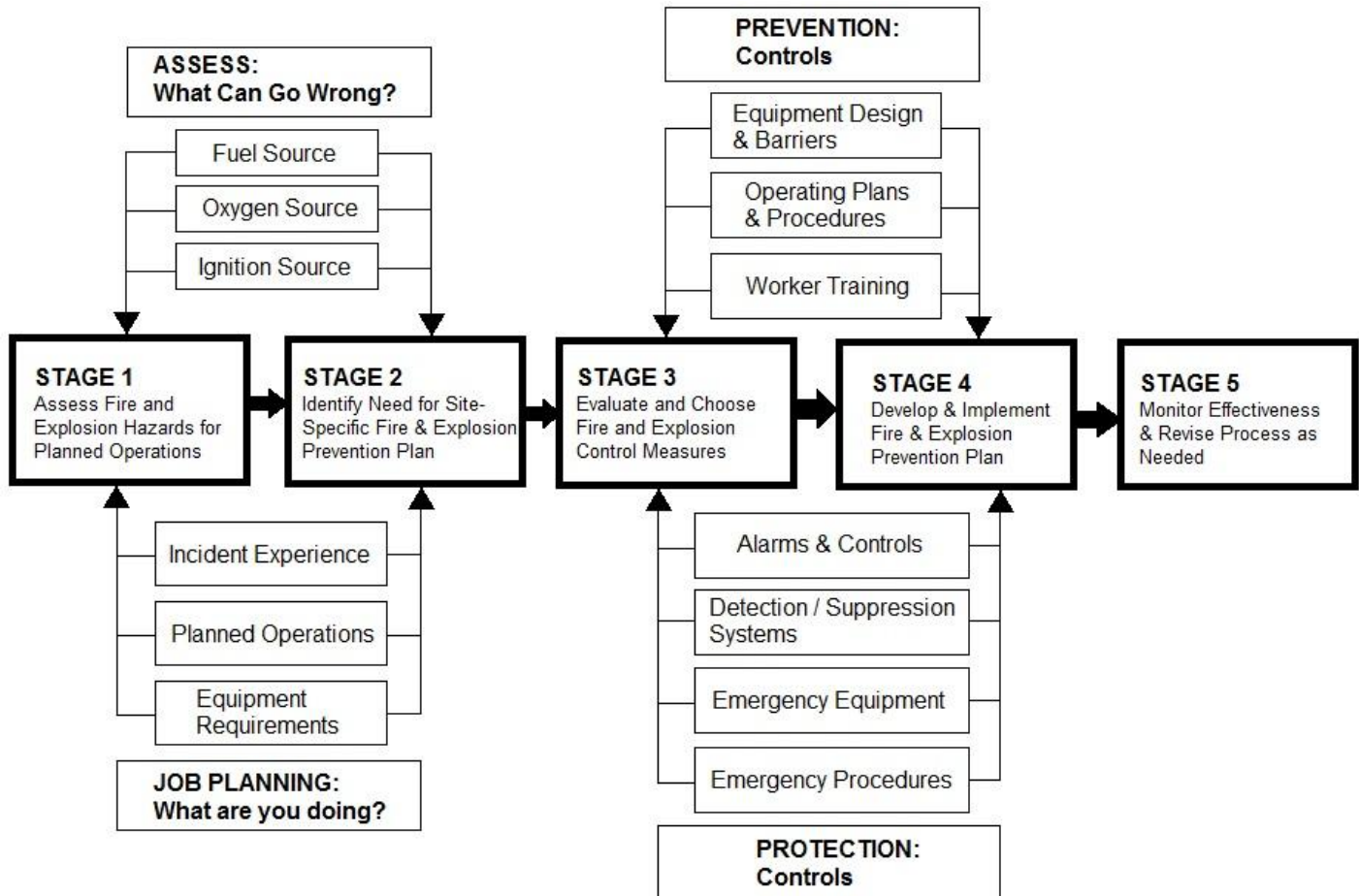

Stage 2: Identify – Document the hazards that exist or have the potential to exist during the scope of work.

Stage 3: Evaluate – Determine which hazards have the most probability, which have the highest exposure, and which have the highest degree of consequence. After you have determined the risk of each hazard, use methods of control listed on the next page to reduce the probability, exposure, and likelihood of a Fire & Explosion incident.

Stage 4: Development – When risk has been assessed and controls have been chosen, document your findings to share with Management and Head Office.

Stage 5: Monitoring - Management will document each process to determine which controls work best in each specific situation. If incidents occur on a more frequent basis, the policies and procedures will be revised to reflect processes needed.



TYPES OF CONTROLS, CONTROL PRIORITIES AND METHODS OF CONTROL

TYPES OF CONTROLS

There are 3 widely recognized types of fire and explosion controls. They all have different functions and are listed in order of effectiveness. For example, engineering controls are more likely to be dependable than the controls that rely on human behaviour.

1. **Engineering Controls:** The goal of engineering controls is to eliminate or reduce the risk of the hazard. It is the preferred type of control as they relate to the design of the process, equipment and tools being used. The functions engineering controls perform are:
 - a) Elimination – (for example, designing equipment that minimizes the release of hazardous substances.
 - b) Substitution – (for example, using non-hydrocarbon fluids when possible)
 - c) Isolation – (for example, enclosing equipment, adding emergency shutdowns)
 - d) Ventilation – (for example, exhausting hazardous substances from the work area)
2. **Administrative Controls:** These address the hazards through the development and application of suitable work systems. The effectiveness of these depends on the integrity of the processes used to develop them and their proper implementation and enforcement. Some examples of administrative controls are development of safe work practices and procedures, job and task training, worker supervision and assessment. All employees are required to have training in Detection & Control of Flammable Substances from an approved third-party safety training company or to take Swab Master Ltd.'s in-house Fire & Explosion Hazard Management (FEHM) program before beginning work.
3. **Personal Protective Equipment (PPE):** Protective equipment is the last line of defense. PPE doesn't control or prevent incidents, but it will protect workers from injury should an incident occur. Fire retardant coveralls are mandatory at Swab Master Ltd., and they are just one example of PPE related to Fire & Explosion Safety.

CONTROL PRIORITIES

The following priorities should be applied to eliminate or control hazards effectively. For some procedures, a combination of the 5 priorities may be required. Lower-level priorities should not be used until higher level priorities have been at least attempted.

1. Design for minimum risk. The top priority should be eliminating hazards in the design process. If a hazard cannot be eliminated, the associated risk needs to be reduced to an acceptable level.
2. Incorporating safety devices. If hazards are not able to be eliminated or reduced to an acceptable level, then fixed, automated or other protective safety equipment or devices should be employed. Routine maintenance and checks of such equipment should be scheduled and documented.
3. Providing warning devices. In the case where the hazards cannot be addressed through design or safety devices, systems or equipment that detect hazardous conditions and provide warnings should be implemented. (For example, 4-head Gas monitors). Warning signals should be designed to help workers react immediately to a hazardous situation.
4. Developing and implementing operating procedures and employee training programs. Where the above methods will not eliminate or reduce hazards to an acceptable level, safe operating procedures should be developed and implemented with safety training programs. Here at Swab Master Ltd., we have safe operating procedures documented in our safety manual for each procedure. We are continuously reviewing and revising these procedures to assess new hazards and reduce risks. Training new employees is an ideal time to evaluate our procedures and revise controls to eliminate or reduce risk.
5. Providing and using personal protective equipment. Employees are given personal protective equipment to prevent injury and illness in the event that all other control measures fail, or an emergency occurs. Employees are trained on the use and maintenance of each piece of PPE and are given responsibility to use said PPE when it is required.



GENERAL METHODS OF CONTROL

1. **Controlling the Fuel / Hydrocarbon sources:** This can be accomplished in 2 ways. The fuel can be physically removed or separated from any oxygen and / or ignition source; or the fuel can be chemically affected by diluting it. For example:
 - Substitute a safer substance when hazardous materials must be used
 - Consider using smaller quantities of hazardous material
 - Control the accumulation of dust, vapor, mist, etc.
 - Store any flammable or combustible substances separately from any ignition source, including smoking, creating sparks (welding, grinding, etc.) or any open flame.
 - Always check the MSDS for reactivity of the chemical or substance you are using. Ensure flammable or combustible substances are stored away from anything that it may react with.
 - Compressed gas containers are to be used, handled, stored, and transported according to the manufacturer's specifications and always protected from damage. They shall be equipped with a valve protection cap if manufactured with such specification.
 - Tank trucks must be flushed at a fluid reclaiming facility after completion of every job. Tank trucks are not permitted to enter the shop / wash bay without prior approval of a manager.
 - When a tank truck is approved for entry into the shop by a manager – all lines and valves must be shut and capped to prevent fumes from escaping
 - When removing equipment from service, purge using an inert substance to reduce the concentration of flammable substance.
 - All flammable substances must be stored in an approved CSA container. All flammable and combustible substances are to be stored in the "Flammable" marked storage container at the main shop location. This storage cabinet is located on the mezzanine on the south side of the building.

2. **Controlling the Air / Oxygen sources:** To control the air / oxygen it is required to displace or reduce the amount of oxygen concentration. This could be accomplished by applying an inert gas such as nitrogen or carbon dioxide since the inert gas will displace the oxygen, thereby lowering concentrations to a level that cannot combust. However, lowering oxygen concentration will affect breathing and will require the use of breathing apparatus or equipment (SCBA or SABA). Other methods of controlling air / oxygen sources are:
 - When preparing vessels and equipment for service, purging with an inert substance to reduce the concentration of oxygen to below the LEL (lower explosive limit)
 - Regular maintenance and cleaning of oxygen cylinders or valves, regulators, or other fittings of the oxygen apparatus or oxygen distributing system should be performed and documented.
 - Follow proper housekeeping protocol and dispose of waste materials (oily rags, spill clean-up waste, etc.) by placing it in the appropriate labelled container. Ensure the container is closed at all times to prevent accidental ignition.
 - Separating hazardous substances, components or operations from other work activities, areas and from personnel. Compressed gas containers shall not be stored in the same area as a cylinder of compressed oxygen.
 - Exhaust fan must be activated when using the wash bay at the main location.
 - Locating equipment so that access during operations, maintenance or repair minimizes the exposure of personnel (for example: hazardous chemicals or high voltage).
 - Providing warning systems that detect unwanted hazardous material releases (for example: 4-Head Gas Monitors). All Swab Master Ltd. personnel are not permitted to enter or remain in a work area if more than 10% of the LEL of an explosive substance is present in the atmosphere.



3. **Controlling the Energy / Ignition sources:** Energy must be absorbed to be controlled. Combustion is a rapid chemical combination of a substance with oxygen that involves the production of heat & light. If the energy emitted by the reaction can be absorbed faster than the reaction can produce the energy, then the reaction cannot be sustained. Alternative methods for limiting the amount of ignition energy could be:
- Reducing the action or potential energy input.
 - There is no smoking permitted at the Swab Master Ltd. main location. Smoking on field lease locations will be determined by the prime contractor protocols. When no prime contractor representative is available, Swab Master Ltd. smoking protocols will be in effect. No smoking within 10 meters of a flammable or combustible substance. Smoking will be allowed at the muster point on a field location, provided it is 10 meters from any hydrocarbon sources. Never smoke while fueling a vehicle.
 - Using the minimum amount of energy to reduce the possibility of an ignition source.
 - Ensure you are aware of the hydrocarbons in your workspace prior to engaging in hot work.
 - Reducing operating speed.
 - Install an automatic engine air shut off on diesel engines rather than operator-activated systems. Automated systems activate when an engine “races” therefore will limit the amount of energy created by this ignition source.
 - Protecting stored energy and hazardous materials from the possibility of shock. All conductive containers (including tank trucks) are to be electrically grounded during transfer of hydrocarbons. Ensure you are familiar with the Grounding and Bonding industry practice listed in Section 9: Transportation.
4. **Inhibiting chemical reactions:** Chemical reactions may be obstructed by introducing a chemical agent into a potentially explosive atmosphere. Certain chemical agents can interfere with reactions by absorbing the free radicals from one sequence that are needed to complete the next (for example, dry chemical extinguishing agents used in portable fire extinguishers). Other methods for inhibiting chemical reactions could include:
- Providing safety and bleed off valves.
 - Reducing the burning rate of a certain chemical (using an inhibitor).
 - All Rigs and Tank Trucks will be equipped with portable or fixed fire extinguishers (Class A, B, and C, D). The shop / office will have the appropriate fire extinguishers as well. Ensure you are familiar with the Emergency Response Plan and always be aware of the location of fire extinguishers.
 - Employing other special systems and / or extinguishing agents.
 - Use a less hazardous type of chemical if available.

FIRE & EXPLOSION INCIDENTS & FOLLOW UP

The main goal at Swab Master Ltd. is to effectively eliminate all risk of a fire or explosion incident. Unfortunately, due to human error and oversight this is not always possible. If all pre job assessments, prevention planning, controls, and PPE fail, and an incident does occur, the top priority to Swab Master Ltd. will be the employee involved.

An incident report should be done immediately by the person(s) involved in the incident. Any witnesses must also fill out a witness statement to complement the incident report. If the main person(s) is not able to fill out a report due to injury, it should be done as soon as humanly possible. Management should be notified immediately.

Upon receiving the reports, management will investigate if necessary to conclude that all preventative measures were taken, and safe work procedures were followed. The goals of the investigation will be to determine:

- What went wrong?
- Were the hazards established before work began?
- What factors caused the incident?
- What preventative measures could have helped?
- What can be done to correct this error?
- Was training a factor?
- What controls were used and how did they fail?
- Was this related to human error or mechanical failure?
- Going forward, which procedure or policy should be adjusted if any?

